

PLAN VIEW

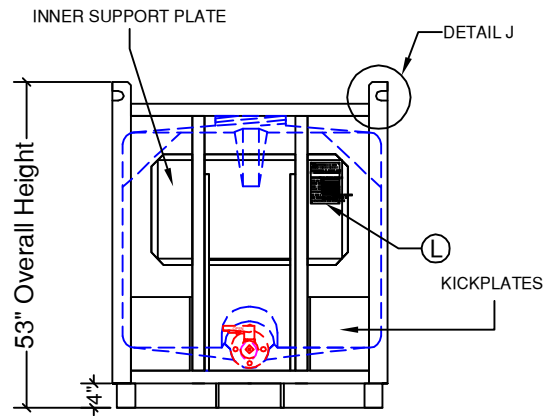

FRONT VIEW

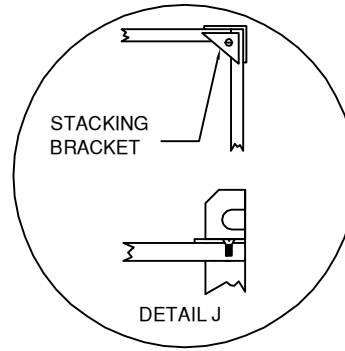
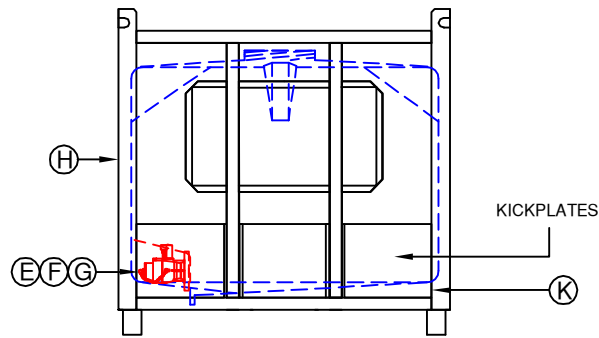

SIDE VIEW

MATERIALS LIST			
ITEM	SIZE	DESCRIPTION	NOTES
A		250 IG (1130 L) POLYETHYLENE BOTTLE	
B	10"	THREADED LID W/ TIE-DOWN	
C		LID GASKET	EPDM OR VITON
D		VENT - VACUUM & PRESSURE RELIEF (OPTIONAL)	IN LID
E	2"	FLANGE GASKET	EPDM OR VITON
F	2"	BALL VALVE; POLYPROPYLENE OR 316-SS	FNPT OR CAMLOC
G		VALVE MOUNTING HARDWARE KIT	
H		STEEL FRAME WITH 12" KICKPLATES AND VALVE PROTECTION GATE	
J		FRAME CORNER STACKING BRACKET W/ SCREW	4 PCS REQUIRED
K		BLACK POLY FRAME PILLOW	
L		ALUMINUM U.N. FRAME TAG	

TECHNICAL DATA:
 1. CAPACITY: 250 IMP GAL, 1130 L
 2. WEIGHT: 590 LBS, 266 KG (APPROX) EMPTY
 3. PRIMARY MARKINGS: 31HA1/Y/

REV	DATE	DESCRIPTION	BY	APPD	REVD
REVISIONS					

CUSTOMER

TITLE

ACO JOB NO:
 PURCHASE ORDER NO:
 PURCHASER'S EQUIP. NO:

THIS DRAWING IS THE PROPERTY OF ACO CONTAINER SYSTEMS LTD. AND SHALL NOT BE COPIED OR TRANSFERRED WITHOUT THE WRITTEN CONSENT OF ACO CONTAINER SYSTEMS LTD.

ENGINEERS SEAL

ACO CONTAINER SYSTEMS LTD.

PICKERING - ONTARIO - CANADA

ACO CONTAINER SYSTEMS LTD.
 794 MCKAY RD.
 PICKERING, ONTARIO, CANADA
 L1W 2Y4
 TEL. 905-683-8222
 FAX 905-683-2969

DESIGNED	S.A.
DRAWN	D.G.
CHECKED	
APPROVED	
SCALE	N.T.S.
DATE	04-09-07

DWG No: PTC-250 LP

REV 0