

TOP VIEW

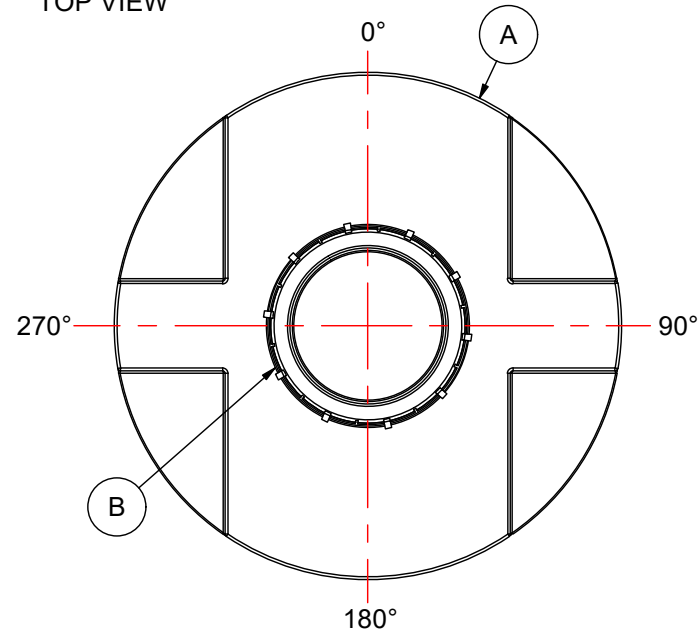

NOTES:

1. TANK IS MANUFACTURED FROM POLYETHYLENE (PE) OR CROSSLINK PE (XLPE).
2. RATED FOR STORING LIQUIDS WITH A SPECIFIC GRAVITY (DENSITY) OF 1.5SG. (1.9SG OR 2.2SG ALSO AVAILABLE)
3. ALL TANK DIMENSIONS ARE SUBJECT TO A +/-3% TOLERANCE.
4. ALL EXTERNAL PIPING AND ACCESSORIES MUST BE FULLY SUPPORTED AND FLEXIBLE TO AVOID STRESSING THE TANK.
5. FITTING GASKETS AVAILABLE IN EPDM OR VITON.
6. TANK MUST BE PROPERLY VENTED TO PREVENT PRESSURE OR VACUUM FROM DEVELOPING AS THE TANK IS FILLING OR EMPTYING.
7. TANK IS MANUFACTURED TO ASTM-D-1998 STANDARD.

MATERIALS LIST		
ITEMS	DESCRIPTION	NOTES
A	CT-500-CH CLOSED TOP TANK	
B	16" LID WITH LOCKING STRAP	

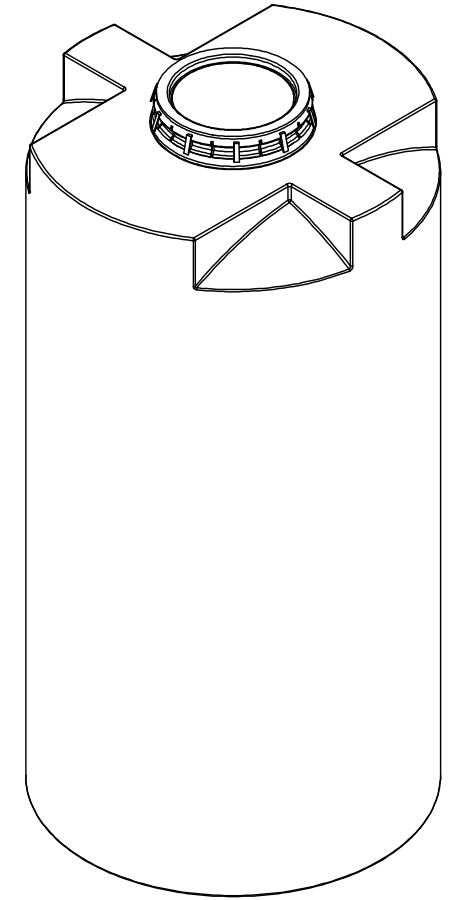
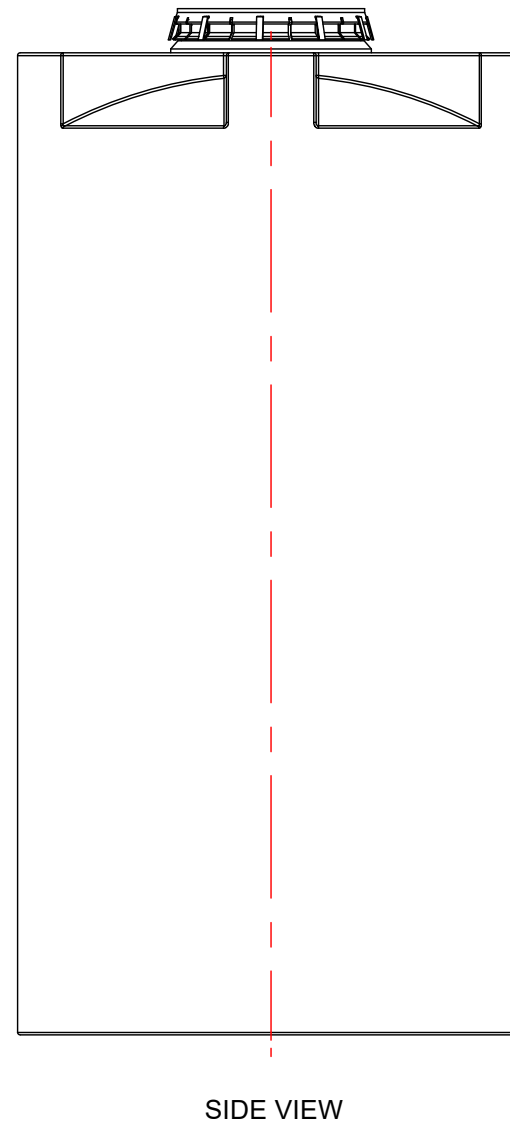
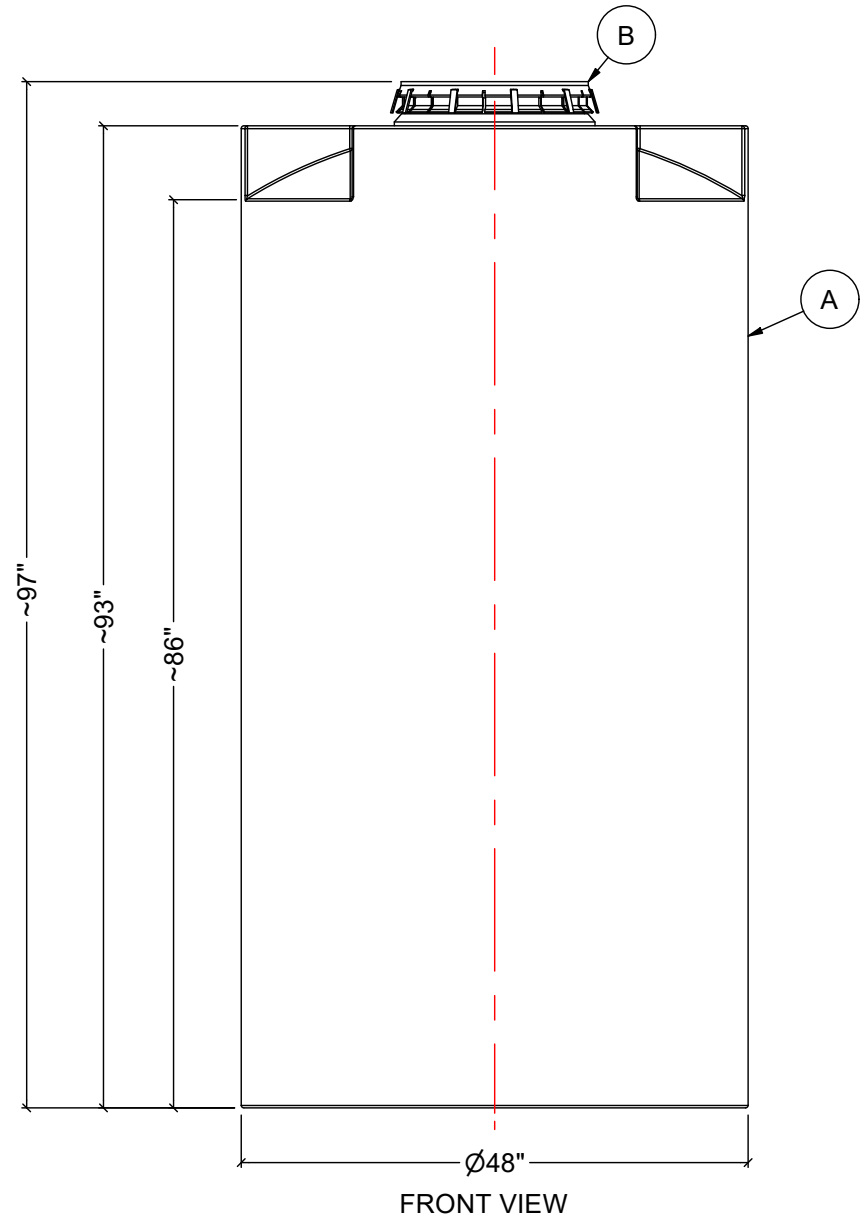

REV	DATE	DESCRIPTION	BY	APPD	REVD
REVISIONS					
CUSTOMER					
TITLE		ACO JOB NO:			
500 IG / 600 USG / 2200 L		PURCHASE ORDER NO:			
CLOSED TOP TANK		PURCHASER'S EQUIP. NO:			
THIS DRAWING IS THE PROPERTY OF ROTOPLAST INC. AND SHALL NOT BE COPIED OR TRANSFERRED WITHOUT THE WRITTEN CONSENT OF ROTOPLAST INC.		 ACO CONTAINER SYSTEMS <i>A division of Rotoplast Inc.</i>			
ENGINEERS SEAL		ACO CONTAINER SYSTEMS DIVISION OF ROTOPLAST INC. 794 MCKAY ROAD PICKERING, ONTARIO, CANADA TEL: 905-683-8222 WEB: ACOTAINERS.COM		DESIGNED	WM
				DRAWN	
				CHECKED	
				APPROVED	
				SCALE	N.T.S.
				DATE	NOV-17-2023
DWG No		CT-500-CH-2024			REV 0