

- NOTES:
1. TANK IS MANUFACTURED FROM POLYETHYLENE (PE) OR CROSSLINK PE (XLPE).
  2. RATED FOR STORING LIQUIDS WITH A SPECIFIC GRAVITY (DENSITY) OF 1.5SG.(1.9SG OR 2.2SG ALSO AVAILABLE)
  3. ALL TANK DIMENSIONS ARE SUBJECT TO A +/-3% TOLERANCE.
  4. ALL EXTERNAL PIPING AND ACCESSORIES MUST BE FULLY SUPPORTED AND FLEXIBLE TO AVOID STRESSING THE TANK.
  5. FITTING GASKETS AVAILABLE IN EPDM OR VITON.
  6. TANK MUST BE PROPERLY VENTED TO PREVENT PRESSURE OR VACUUM FROM DEVELOPING AS THE TANK IS FILLING OR EMPTYING.
  7. TANK IS MANUFACTURED TO ASTM-D-1998 STANDARD.

MATERIALS LIST		
ITEMS	DESCRIPTION	NOTES
A	CT-805 TANK	
B	16" LID WITH LOCKING STRAP	

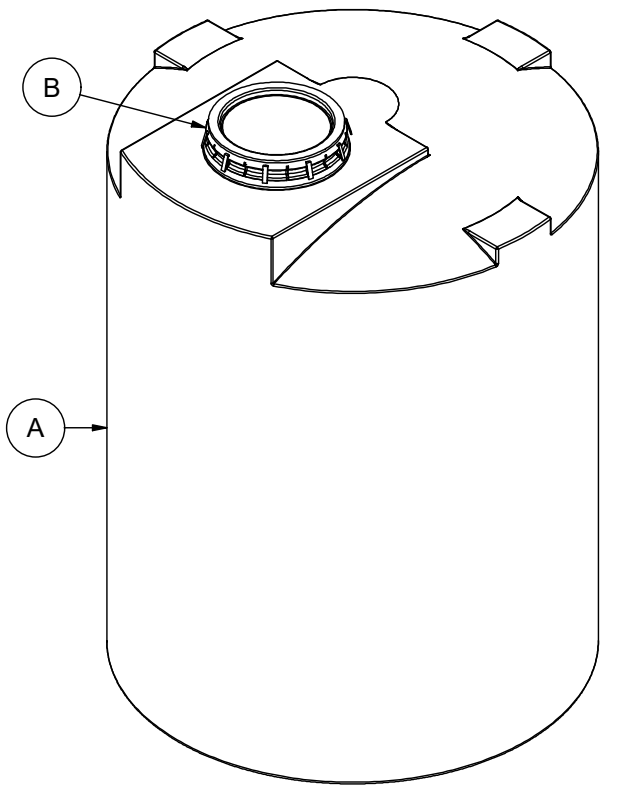
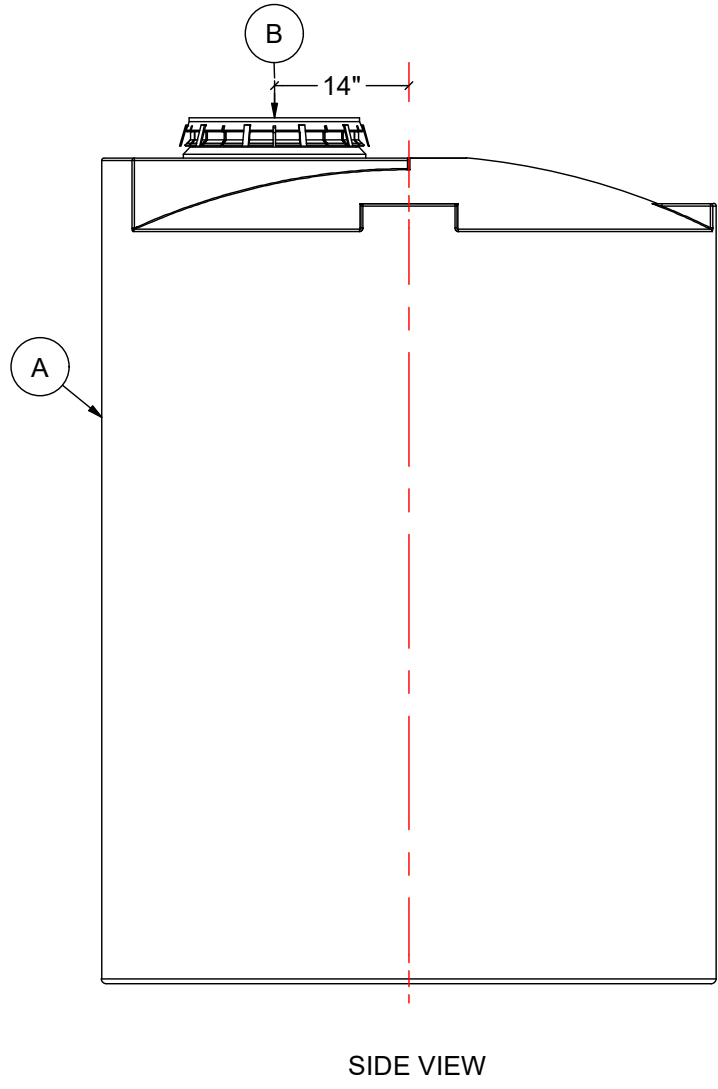
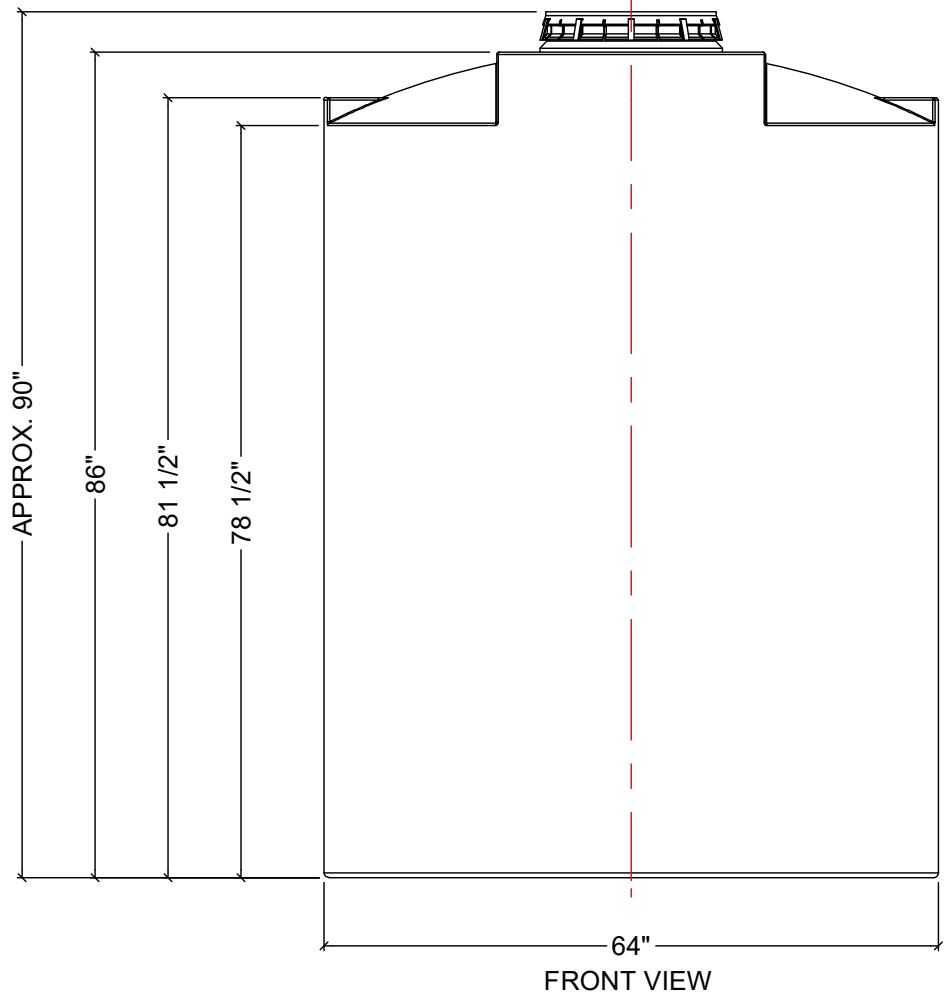

REV	DATE	DESCRIPTION	BY	APPD	REVD
REVISIONS					
CUSTOMER					
TITLE		ACO JOB NO:			
800 IG CLOSED TOP TANK		PURCHASE ORDER NO:			
		PURCHASER'S EQUIP. NO:			
THIS DRAWING IS THE PROPERTY OF ROTOPLAST INC. AND SHALL NOT BE COPIED OR TRANSFERRED WITHOUT THE WRITTEN CONSENT OF ROTOPLAST INC.					
ENGINEERS SEAL		<b>ACO CONTAINER SYSTEMS</b> DIVISION OF ROTOPLAST INC. <small>PICKERING - ONTARIO - CANADA</small> ACO CONTAINER SYSTEMS DIVISION OF ROTOPLAST INC. 794 MCKAY RD. PICKERING, ONTARIO, CANADA TEL. 905-683-8222 FAX 905-683-2969 <small>DWG No</small>			
		DESIGNED		DATE	
		DRAWN		02-03-16	
		CHECKED		N.T.S.	
		APPROVED		REV 0	
		SCALE		CT-805	