

TOP VIEW

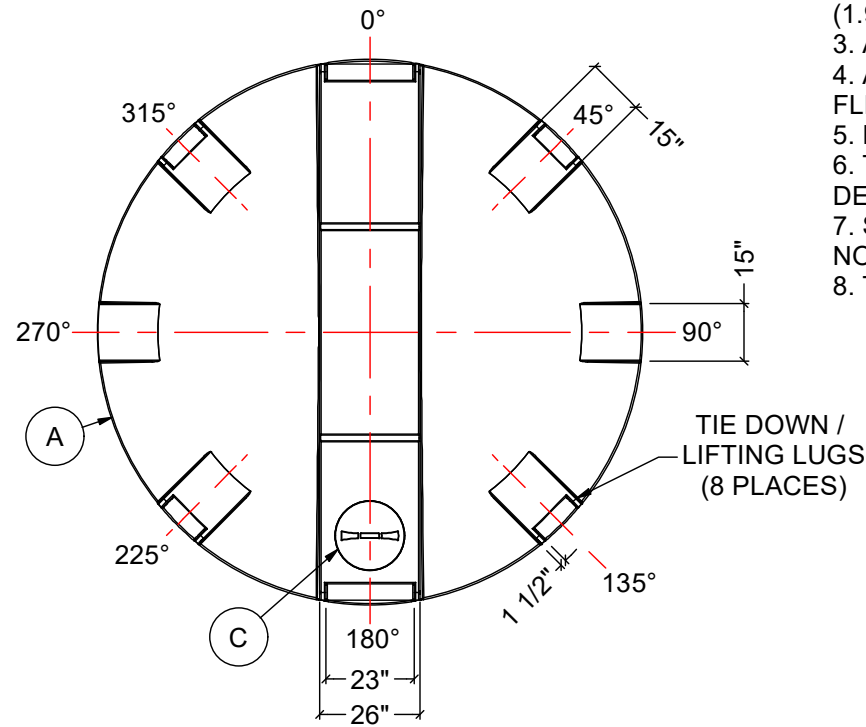

NOTES:

1. TANK IS MANUFACTURED FROM POLYETHYLENE (PE) OR CROSSLINK PE (XLPE).
2. RATING FOR STORING LIQUIDS WITH A SPECIFIC GRAVITY (DENSITY) OF 1.5SG. (1.9SG OR 2.2SG ALSO AVAILABLE)
3. ALL TANK DIMENSIONS ARE SUBJECT TO A +/-3% TOLERANCE.
4. ALL EXTERNAL PIPING AND ACCESSORIES MUST BE FULLY SUPPORTED AND FLEXIBLE TO AVOID STRESSING THE TANK.
5. FITTING GASKETS AVAILABLE IN EPDM OR VITON.
6. TANK MUST BE PROPERLY VENTED TO PREVENT PRESSURE OR VACUUM FROM DEVELOPING AS THE TANK IS FILLING OR EMPTYING.
7. STANDARD LID IS 16" NON-VENTED. LID ALSO AVAILABLE IN 15" OR 21" VENTED OR NON-VENTED.
8. TANK IS MANUFACTURED TO ASTM-D-1998 STANDARD

MATERIALS LIST		
ITEMS	DESCRIPTION	NOTES
A	DCT-8340 PRIMARY TANK	
B	DCT-8340 CONTAINMENT TANK	
C	15" THREADED LID	

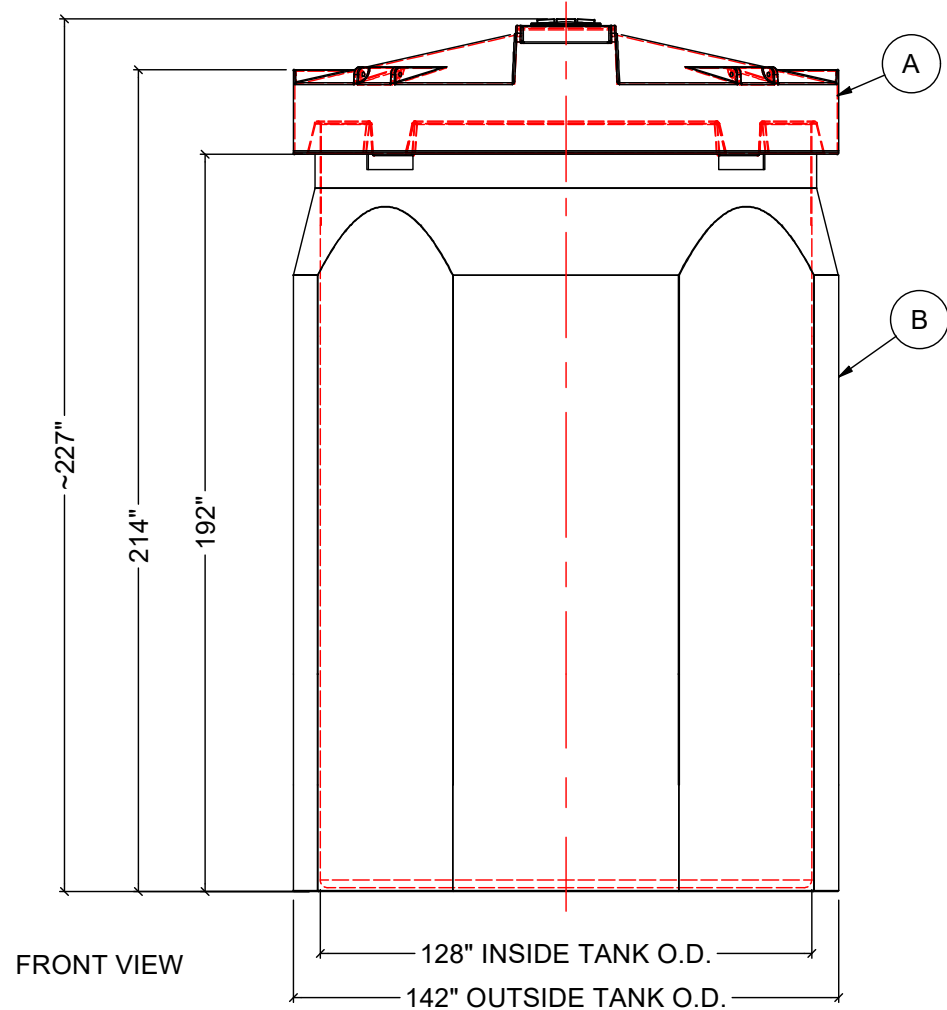
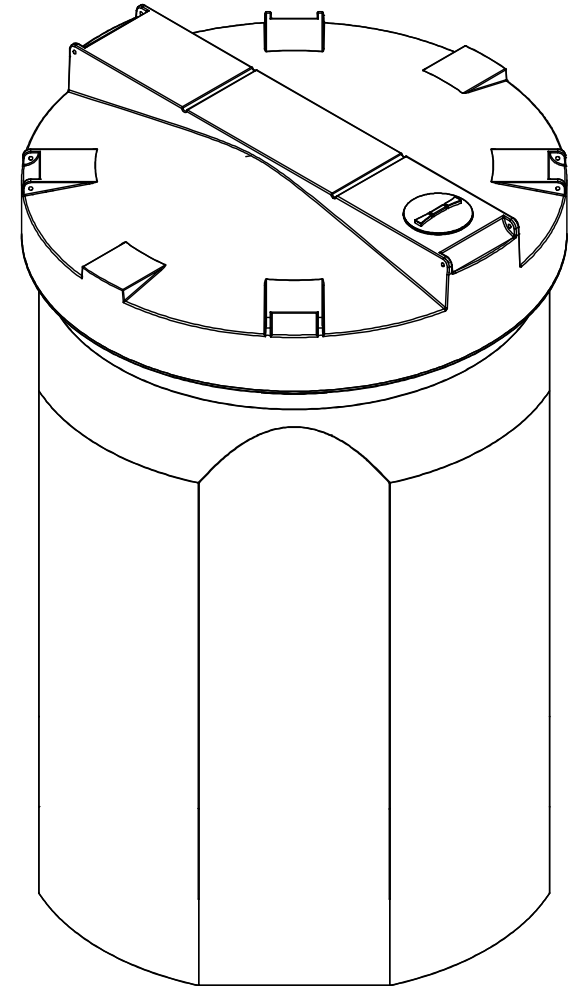

FRONT VIEW

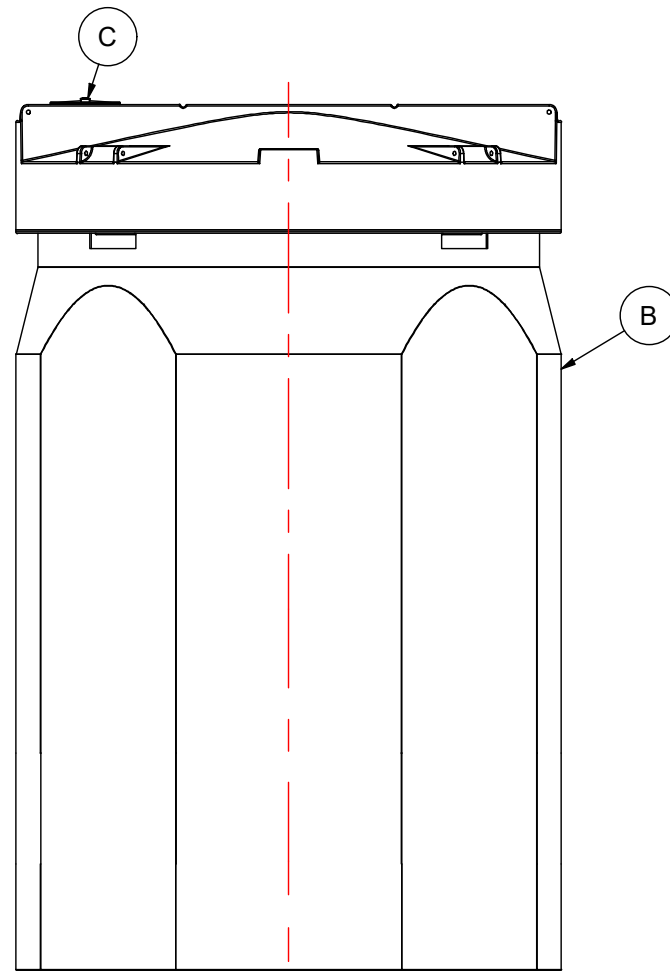

SIDE VIEW

REV	DATE	DESCRIPTION	BY	APPD	REVD
REVISIONS					
CUSTOMER					
TITLE			ACO JOB NO:		
8300 IG DOUBLE WALL TANK			PURCHASE ORDER NO:		
			PURCHASER'S EQUIP. NO:		
THIS DRAWING IS THE PROPERTY OF ROTOPLAST INC. AND SHALL NOT BE COPIED OR TRANSFERRED WITHOUT THE WRITTEN CONSENT OF ROTOPLAST INC.					
ENGINEERS SEAL		<b>ACO CONTAINER SYSTEMS</b> DIVISION OF ROTOPLAST INC.			
<small>PICKERING - ONTARIO - CANADA</small>					
ACO CONTAINER SYSTEMS DIVISION OF ROTOPLAST INC. 794 MCKAY RD. PICKERING, ONTARIO, CANADA TEL. 905-683-8222 FAX 905-683-2969			DESIGNED		
			DRAWN	WM	
			CHECKED		
			APPROVED		
			SCALE	N.T.S.	
			DATE	01-04-16	
DWG No			DCT-8340		REV 0