

- NOTES:
1. TANK IS MANUFACTURED FROM POLYETHYLENE (PE) OR CROSSLINK PE (XLPE).
 2. RATING FOR STORING LIQUIDS WITH A SPECIFIC GRAVITY (DENSITY) OF 1.9SG. (2.2SG ALSO AVAILABLE)
 3. ALL TANK DIMENSIONS ARE SUBJECT TO A +/-3% TOLERANCE.
 4. ALL EXTERNAL PIPING AND ACCESSORIES MUST BE FULLY SUPPORTED AND FLEXIBLE TO AVOID STRESSING THE TANK.
 5. FITTING GASKETS AVAILABLE IN EPDM OR VITON.
 6. TANK MUST BE PROPERLY VENTED TO PREVENT PRESSURE OR VACUUM FROM DEVELOPING AS THE TANK IS FILLING OR EMPTYING.

MATERIALS LIST		
ITEMS	DESCRIPTION	NOTES
A	DMT-100-OUTSIDE TANK	
B	DMT-100-INSIDE TANK	
C	6" THREADED LID	

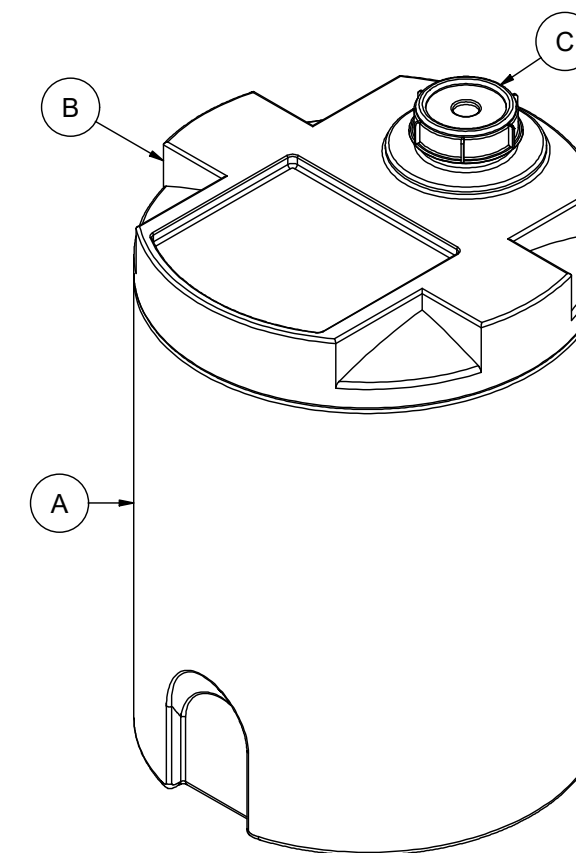
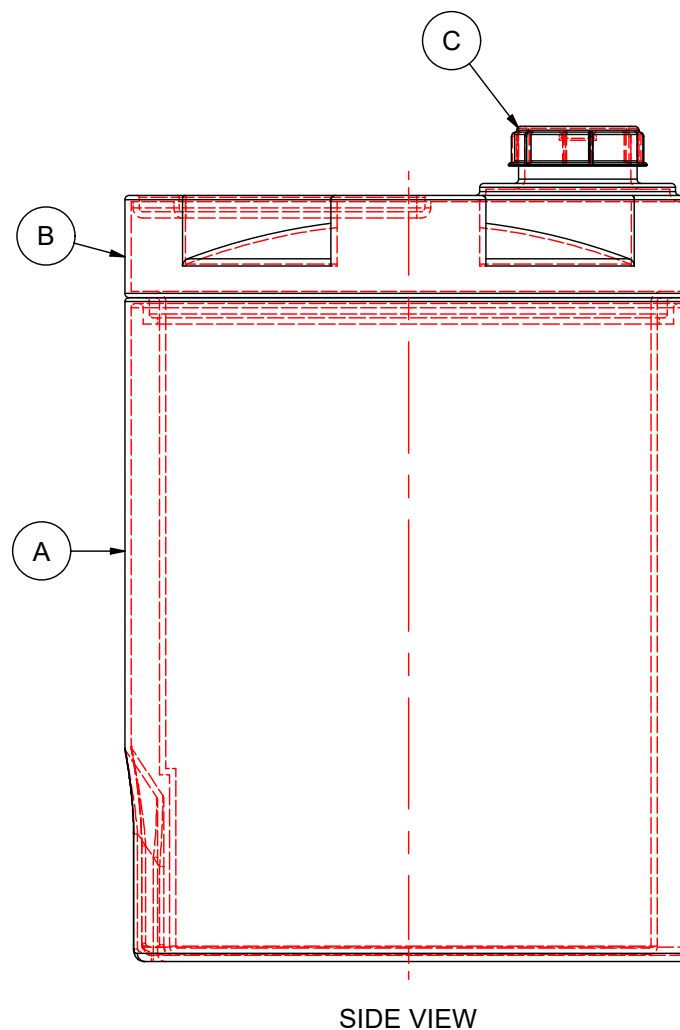
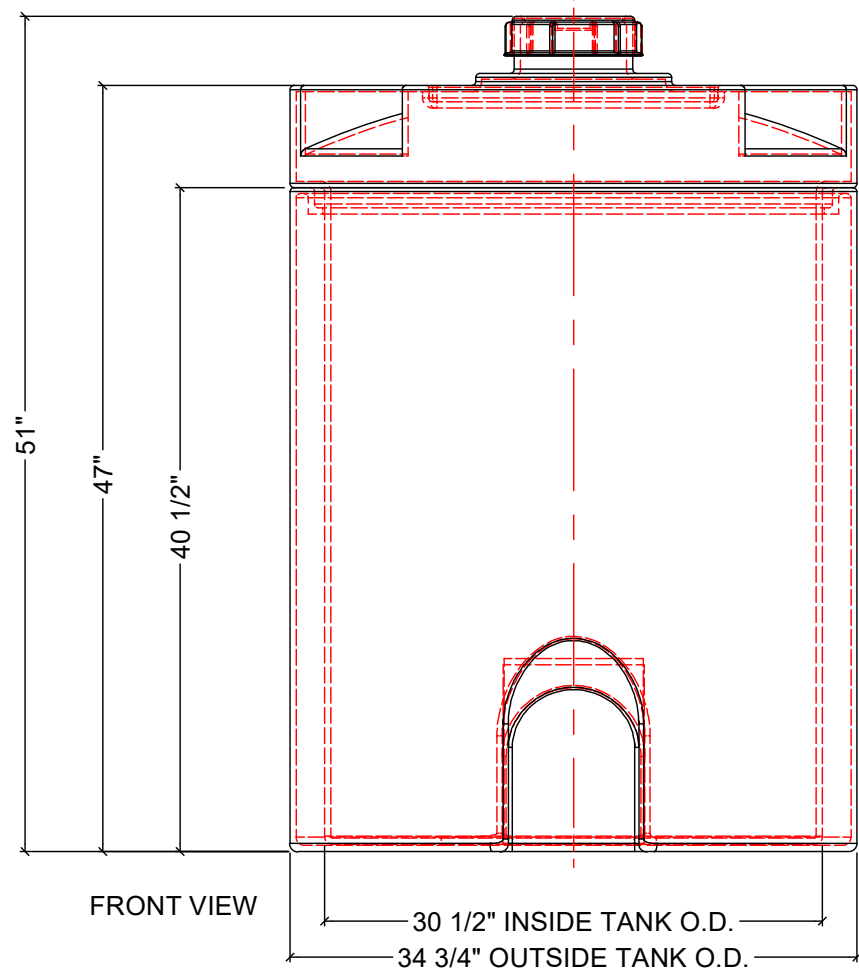

REV	DATE	DESCRIPTION	BY	APPD	REVD
REVISIONS					
CUSTOMER					
TITLE		ACO JOB NO:			
100 IG DOUBLE WALL TANK		PURCHASE ORDER NO:			
		PURCHASER'S EQUIP. NO:			
THIS DRAWING IS THE PROPERTY OF ROTOPLAST INC. AND SHALL NOT BE COPIED OR TRANSFERRED WITHOUT THE WRITTEN CONSENT OF ROTOPLAST INC.					
ENGINEERS SEAL		ACO CONTAINER SYSTEMS DIVISION OF ROTOPLAST INC. <small>PICKERING - ONTARIO - CANADA</small> ACO CONTAINER SYSTEMS DIVISION OF ROTOPLAST INC. 794 MCKAY RD. PICKERING, ONTARIO, CANADA TEL. 905-683-8222 FAX 905-683-2969 <small>DWG No</small>			
		DESIGNED			
		DRAWN	WM		
		CHECKED			
		APPROVED			
		SCALE	N.T.S.		
		DATE	28-03-16		
		DMT-100		REV	0