

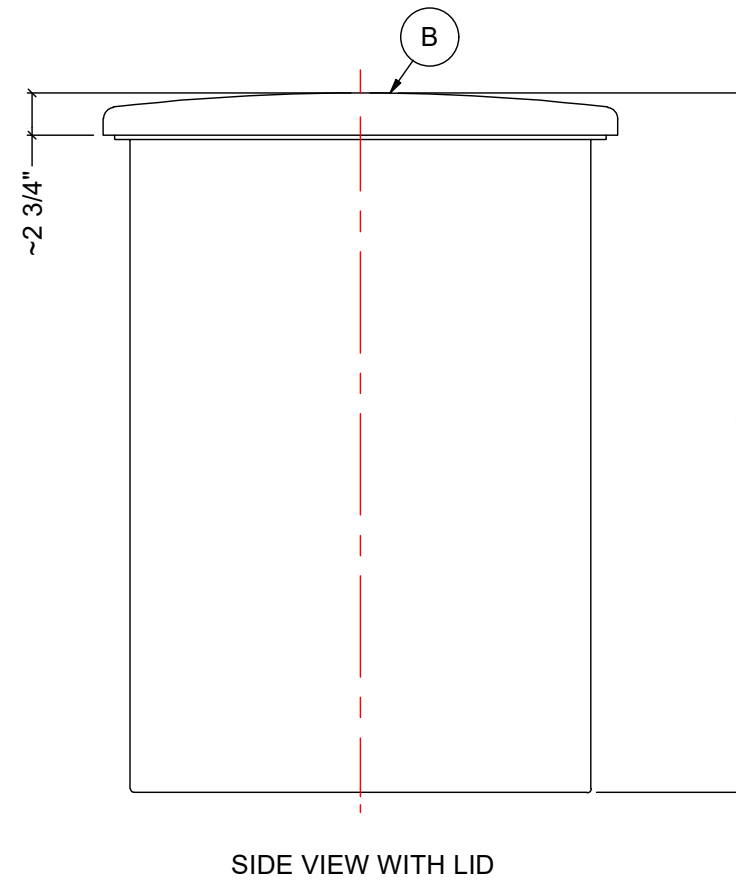

- NOTES:
1. TANK IS MANUFACTURED FROM POLYETHYLENE (HDPE) OR CROSSLINK PE (XLPE).
 2. RATING FOR STORING LIQUIDS WITH A SPECIFIC GRAVITY (DENSITY) OF 1.5SG. (1.9SG OR 2.2SG ALSO AVAILABLE)
 3. ALL TANK DIMENSIONS ARE SUBJECT TO A +/-3% TOLERANCE.
 4. ALL EXTERNAL PIPING AND ACCESSORIES MUST BE FULLY SUPPORTED AND FLEXIBLE TO AVOID STRESSING THE TANK.
 5. FITTING GASKETS AVAILABLE IN EPDM OR VITON.

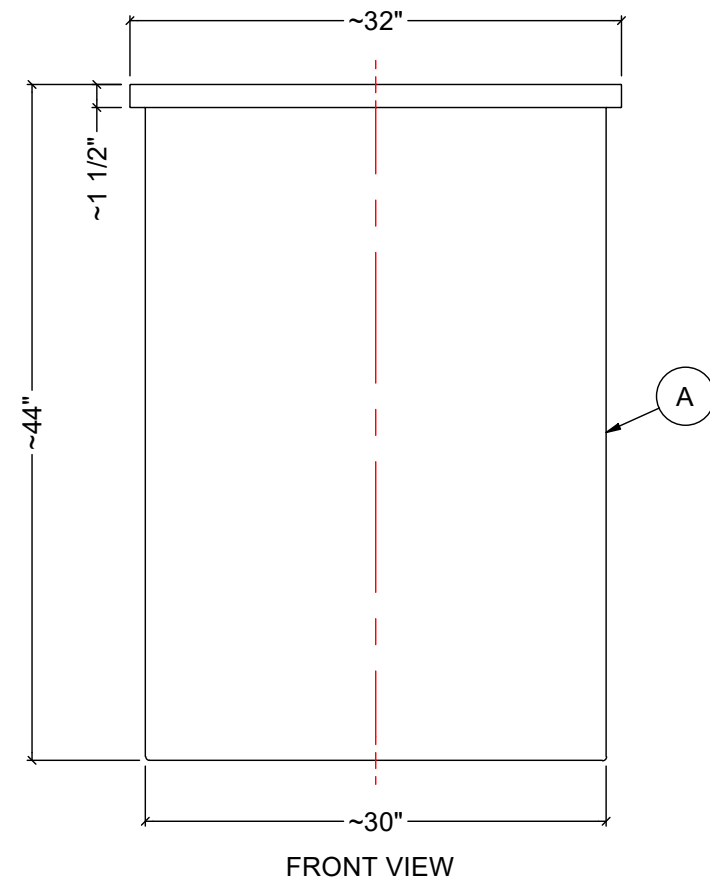

MATERIALS LIST		
ITEMS	DESCRIPTION	NOTES
A	OT-100 OPEN TOP TANK	
B	LID FOR OT-100	

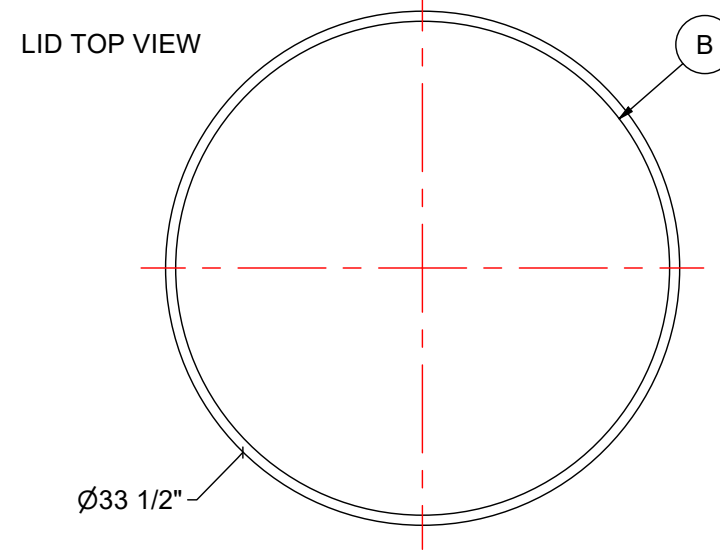
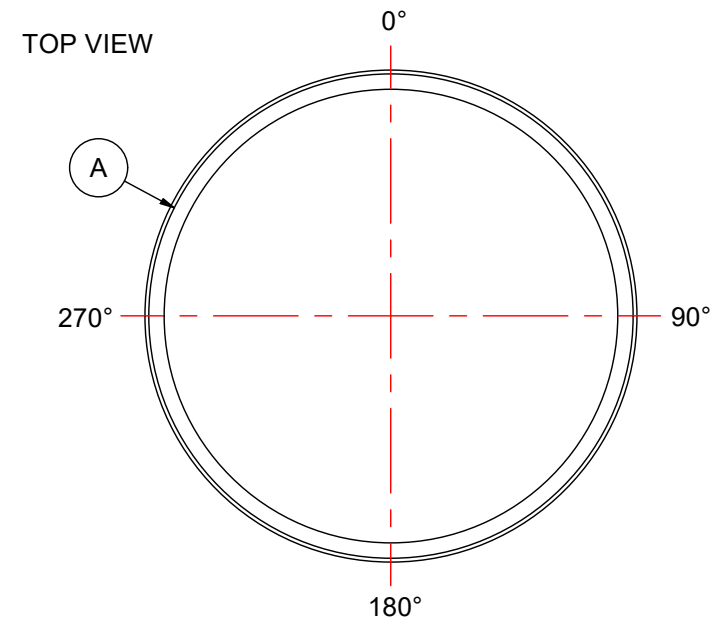
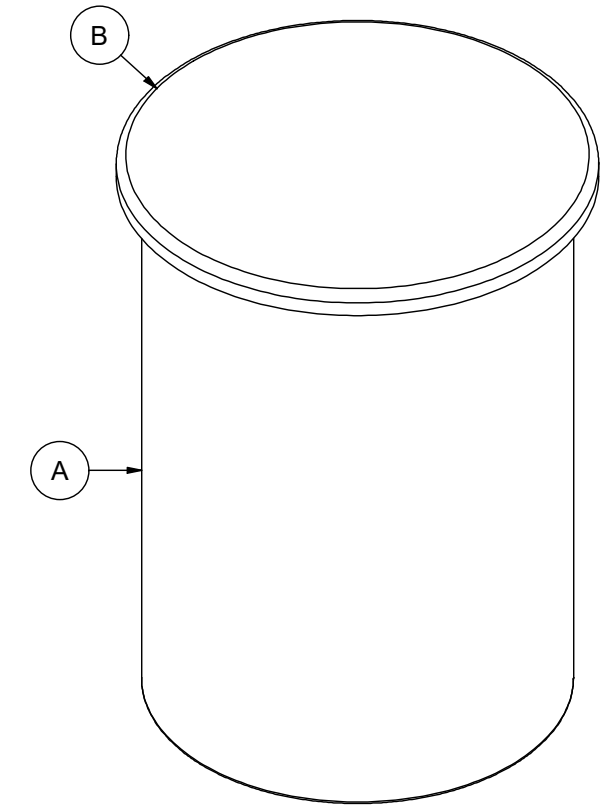

REV	DATE	DESCRIPTION	BY	APPD	REVD
REVISIONS					
CUSTOMER					
TITLE			ACO JOB NO:		
100IG/120USG/450L OPEN TOP TANK WITH LID			PO#:		
			EQUIP. NO:		
THIS DRAWING IS THE PROPERTY OF ROTOPLAST INC. AND SHALL NOT BE COPIED OR TRANSFERRED WITHOUT THE WRITTEN CONSENT OF ROTOPLAST INC.			 A division of Rotoplast Inc.		
DESIGNED			DRAWN		
CHECKED			APPROVED		
SCALE			DATE		
N.T.S.			JAN-28-2019		
DWG No			REV		
OT-100-L			0		