

TOP VIEW

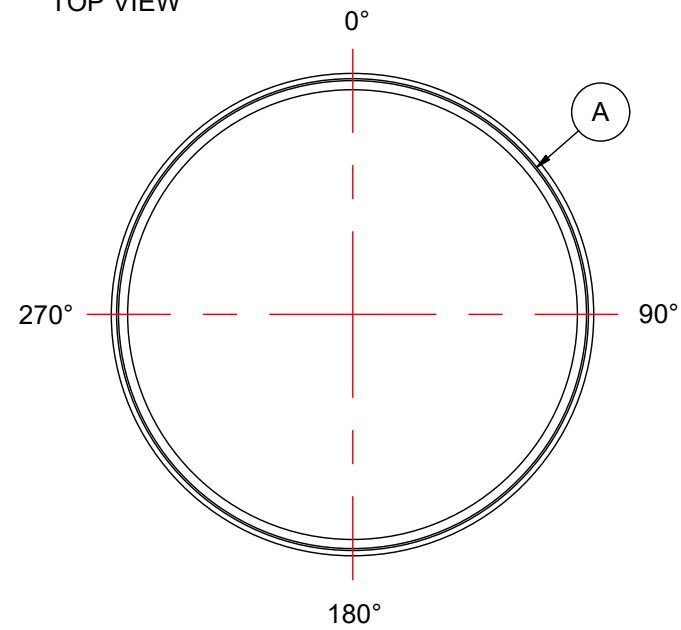

NOTES:

1. TANK IS MANUFACTURED FROM POLYETHYLENE (HDPE)
2. RATING FOR STORING LIQUIDS WITH A SPECIFIC GRAVITY (DENSITY) OF 1.9SG.
3. ALL TANK DIMENSIONS ARE SUBJECT TO A +/-3% TOLERANCE.
4. ALL EXTERNAL PIPING AND ACCESSORIES MUST BE FULLY SUPPORTED AND FLEXIBLE TO AVOID STRESSING THE TANK.
5. FITTING GASKETS AVAILABLE IN EPDM OR VITON.
6. TANK MUST BE PROPERLY VENTED TO PREVENT PRESSURE OR VACUUM FROM DEVELOPING AS THE TANK IS FILLING OR EMPTYING.

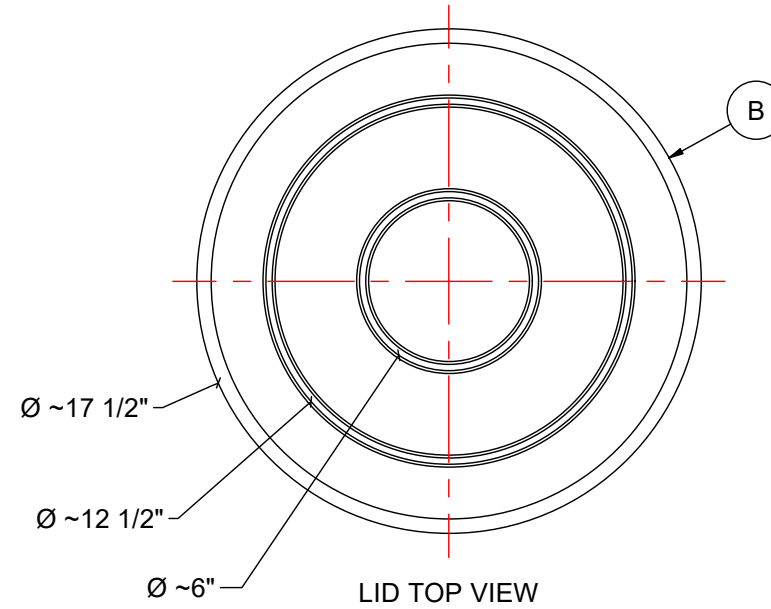

LID TOP VIEW

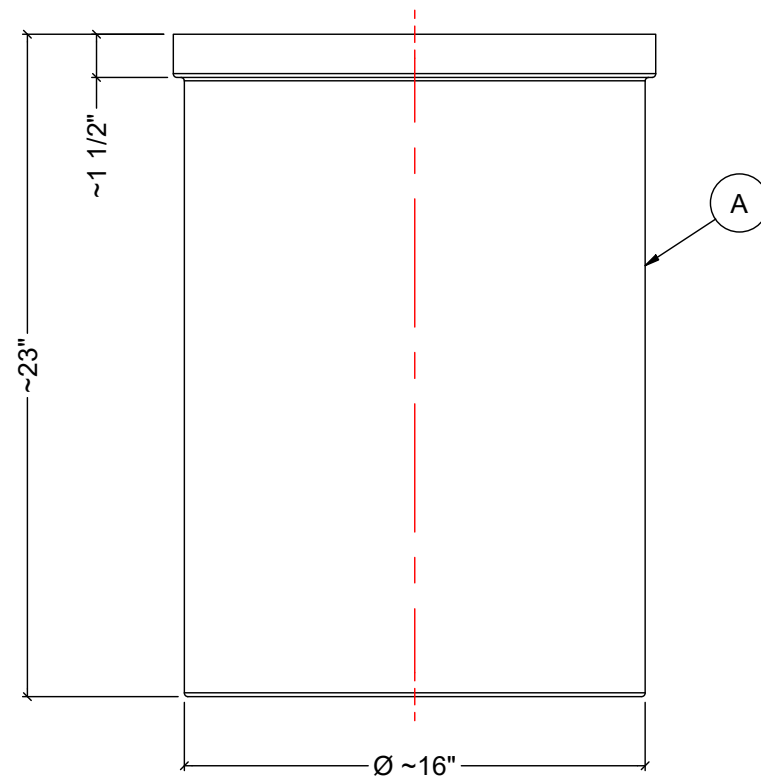

FRONT VIEW

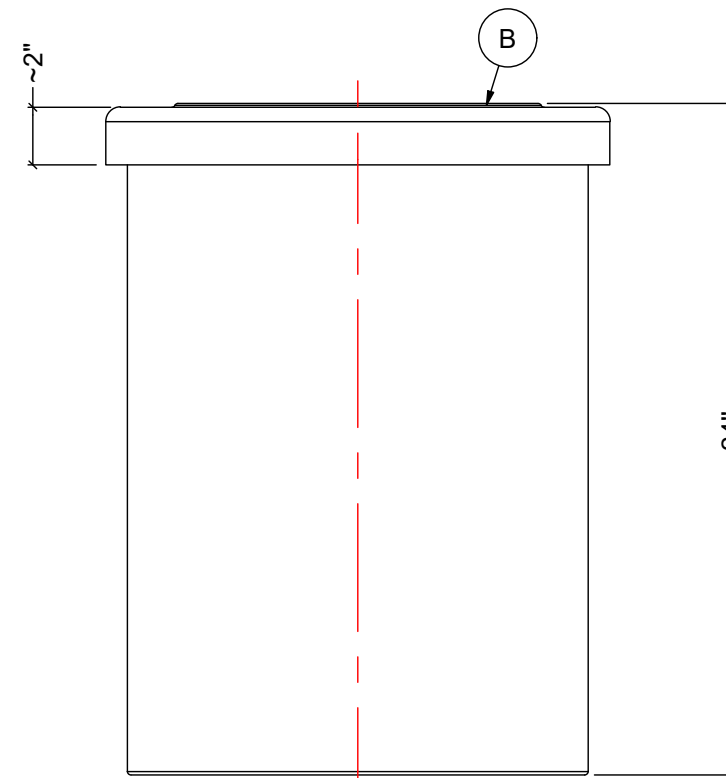

SIDE VIEW

MATERIALS LIST

ITEMS	PART#	DESCRIPTION	NOTES
A	OT-15	(15 IG / 18 USG / 68 L) OPEN TOP TANK	
B	OT-15-L	REMOVABLE LID FOR OT-15	

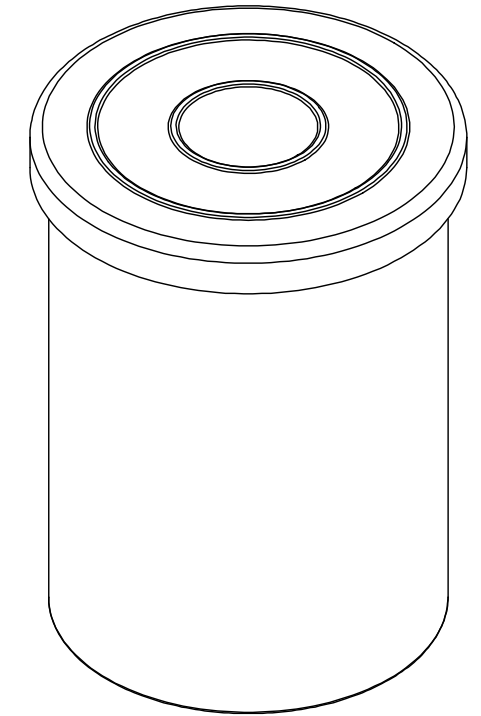

REV	DATE	DESCRIPTION	BY	APPD	REVD
REVISIONS					

CUSTOMER

TITLE	ACO JOB NO:
15 IG / 18 USG / 68L OPEN TOP TANK w/ LID	PO#:
	EQUIP. NO:

THIS DRAWING IS THE PROPERTY OF ROTOPLAST INC. AND SHALL NOT BE COPIED OR TRANSFERRED WITHOUT THE WRITTEN CONSENT OF ROTOPLAST INC.



ENGINEERS SEAL	ACO CONTAINER SYSTEMS DIVISION OF ROTOPLAST INC. 794 MCKAY ROAD PICKERING, ONTARIO, CANADA TEL: 905-683-8222 WEB: ACOTAINERS.COM	DESIGNED	GT
		DRAWN	
		CHECKED	
		APPROVED	
		SCALE	N.T.S.
		DATE	NOV-21-2023