

- NOTES:
 1. TANK IS MANUFACTURED FROM POLYETHYLENE (HDPE) OR CROSSLINK PE (XLPE).
 2. RATING FOR STORING LIQUIDS WITH A SPECIFIC GRAVITY (DENSITY) OF 1.5SG. (1.9SG OR 2.2SG ALSO AVAILABLE)
 3. ALL TANK DIMENSIONS ARE SUBJECT TO A +/-3% TOLERANCE.
 4. ALL EXTERNAL PIPING AND ACCESSORIES MUST BE FULLY SUPPORTED AND FLEXIBLE TO AVOID STRESSING THE TANK.
 5. FITTING GASKETS AVAILABLE IN EPDM OR VITON.

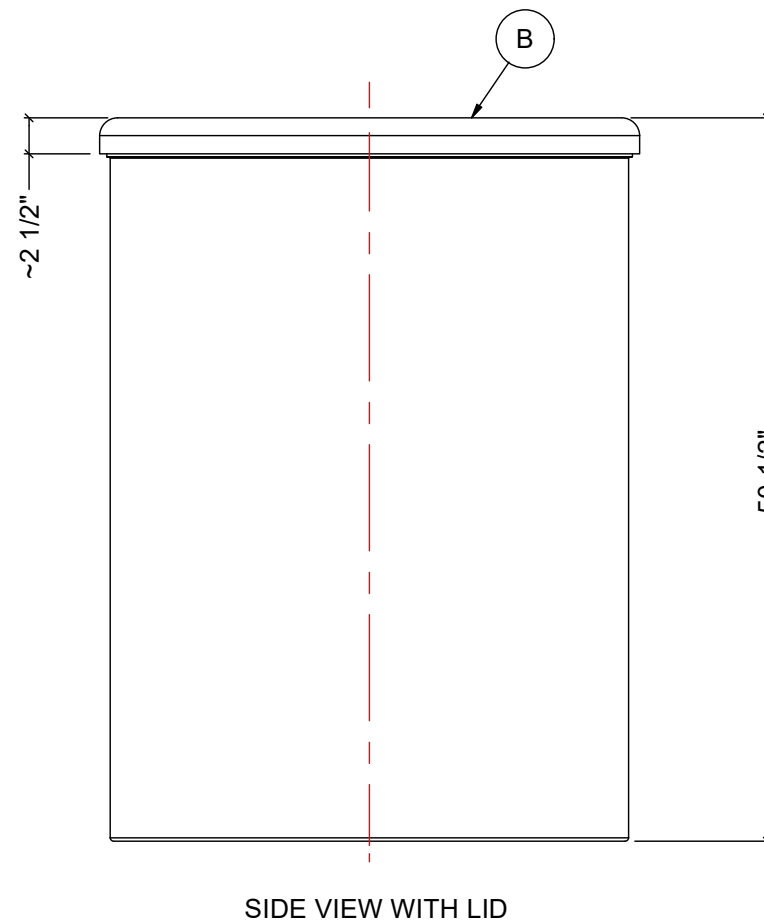

MATERIALS LIST		
ITEMS	DESCRIPTION	NOTES
A	OT-175 OPEN TOP TANK	
B	LID FOR OT-175	

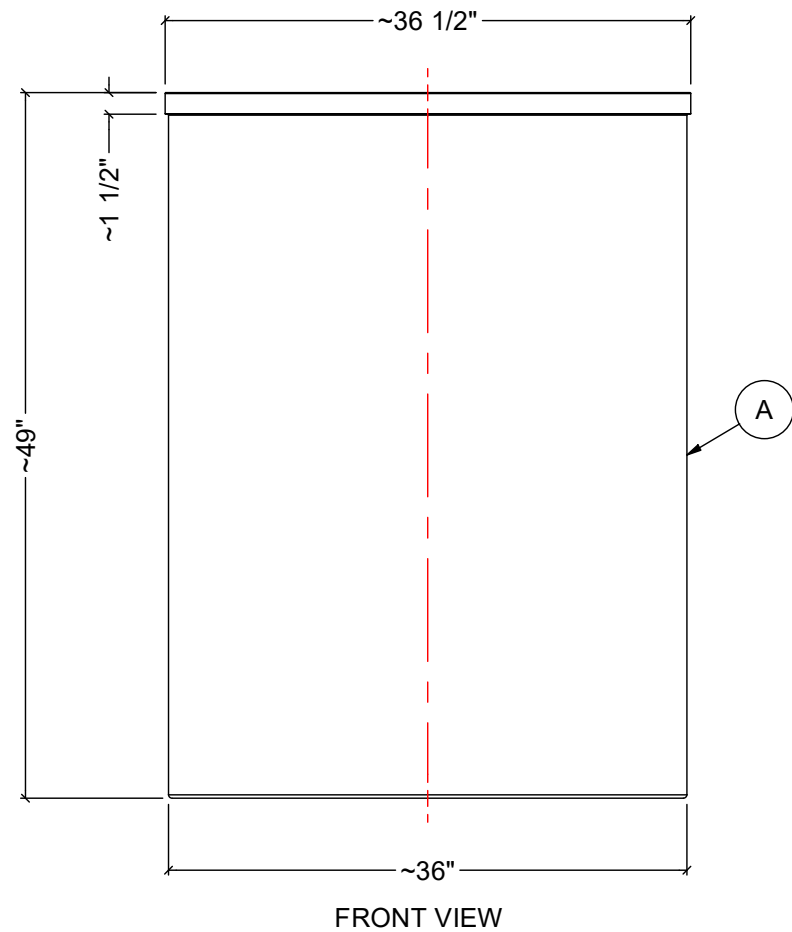
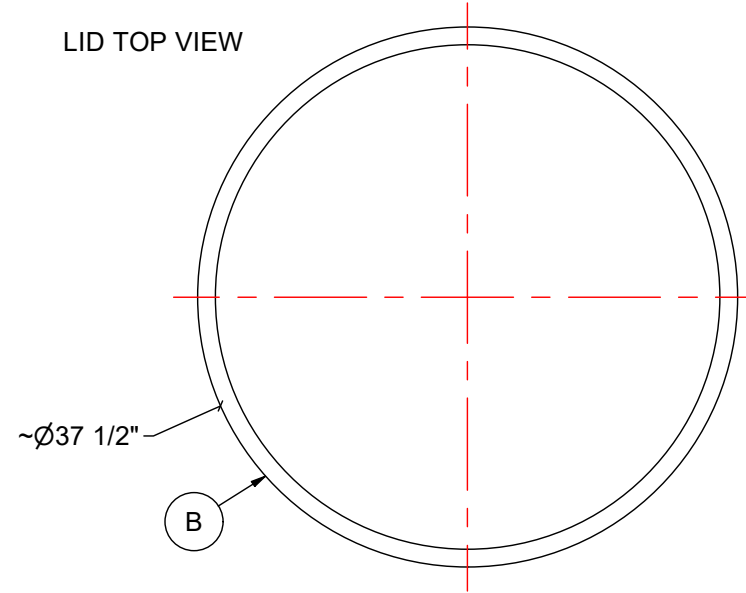
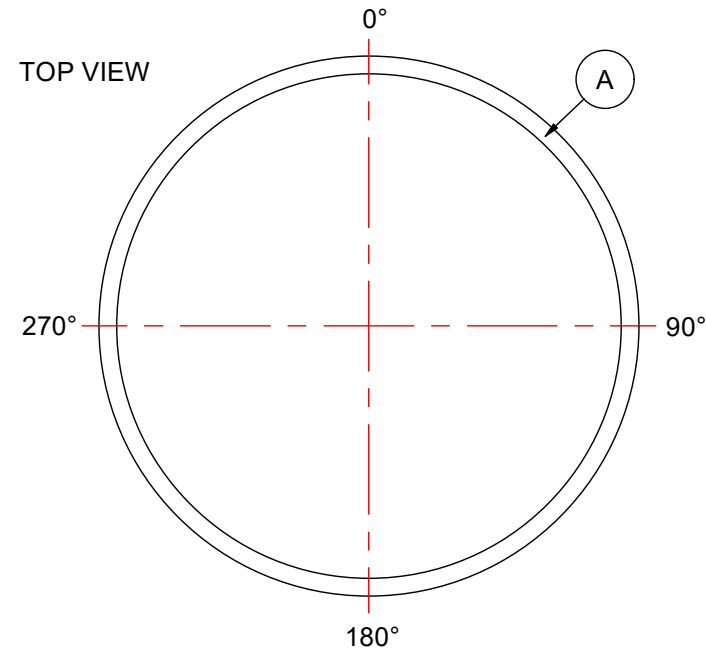
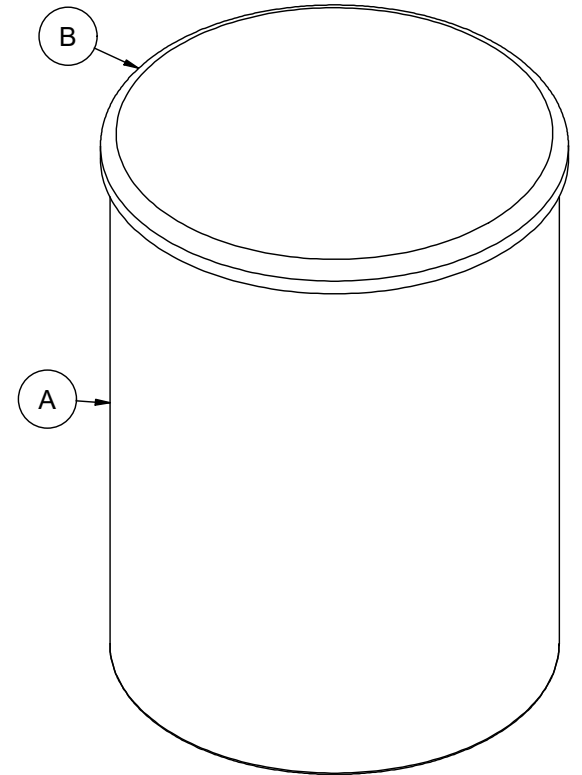

REV	DATE	DESCRIPTION	BY	APPD	REVD
REVISIONS					
CUSTOMER					
TITLE		ACO JOB NO:			
175 IG OPEN TOP TANK		PURCHASE ORDER NO:			
		PURCHASER'S EQUIP. NO:			
THIS DRAWING IS THE PROPERTY OF ROTOPLAST INC. AND SHALL NOT BE COPIED OR TRANSFERRED WITHOUT THE WRITTEN CONSENT OF ROTOPLAST INC.					
ENGINEERS SEAL		ACO CONTAINER SYSTEMS DIVISION OF ROTOPLAST INC.			
<small>PICKERING - ONTARIO - CANADA</small>					
<small>ACO CONTAINER SYSTEMS DIVISION OF ROTOPLAST INC. 794 MCKAY RD. PICKERING, ONTARIO, CANADA TEL. 905-683-8222 FAX 905-683-2969</small>		<small>DESIGNED</small>	<small>DRAWN</small>	<small>CHECKED</small>	<small>APPROVED</small>
			WM		
		<small>SCALE</small>	<small>DATE</small>	<small>N.T.S.</small>	<small>08-03-16</small>
<small>DWG No</small>		OT-175-L			<small>REV</small> 0