

- NOTES:
1. TANK IS MANUFACTURED FROM POLYETHYLENE (PE) OR CROSSLINK PE (XLPE).
 2. RATING FOR STORING LIQUIDS WITH A SPECIFIC GRAVITY (DENSITY) OF 1.5SG. (1.9SG OR 2.2SG ALSO AVAILABLE)
 3. ALL TANK DIMENSIONS ARE SUBJECT TO A +/-3% TOLERANCE.
 4. ALL EXTERNAL PIPING AND ACCESSORIES MUST BE FULLY SUPPORTED AND FLEXIBLE TO AVOID STRESSING THE TANK.
 5. FITTING GASKETS AVAILABLE IN EPDM OR VITON.
 6. TANK MUST BE PROPERLY VENTED TO PREVENT PRESSURE OR VACUUM FROM DEVELOPING AS THE TANK IS FILLING OR EMPTYING.

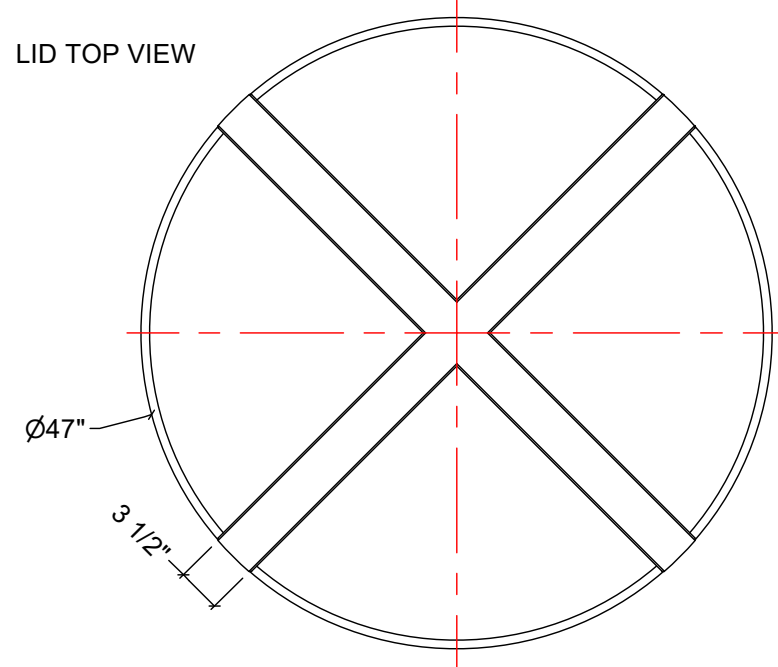

MATERIALS LIST		
ITEMS	DESCRIPTION	NOTES
A	OT-240 OPEN TOP TANK	
B	LID FOR OT-240	

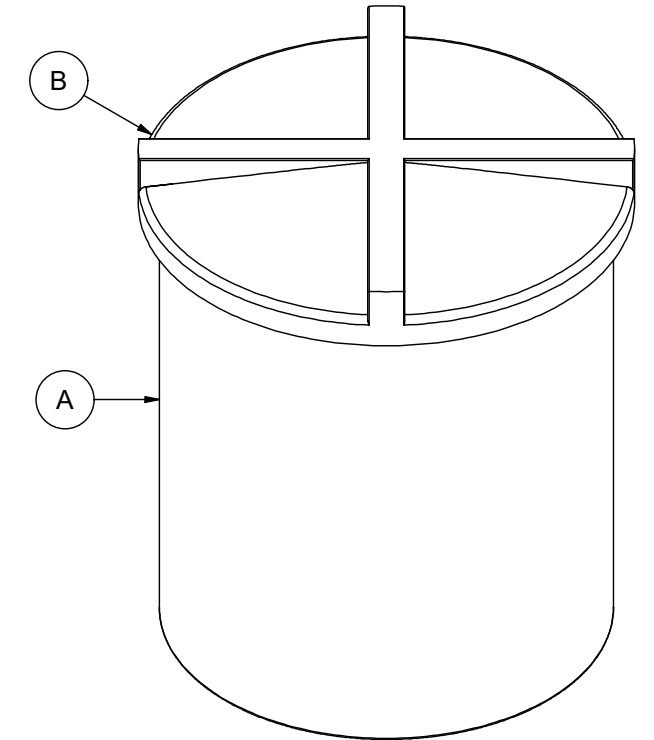
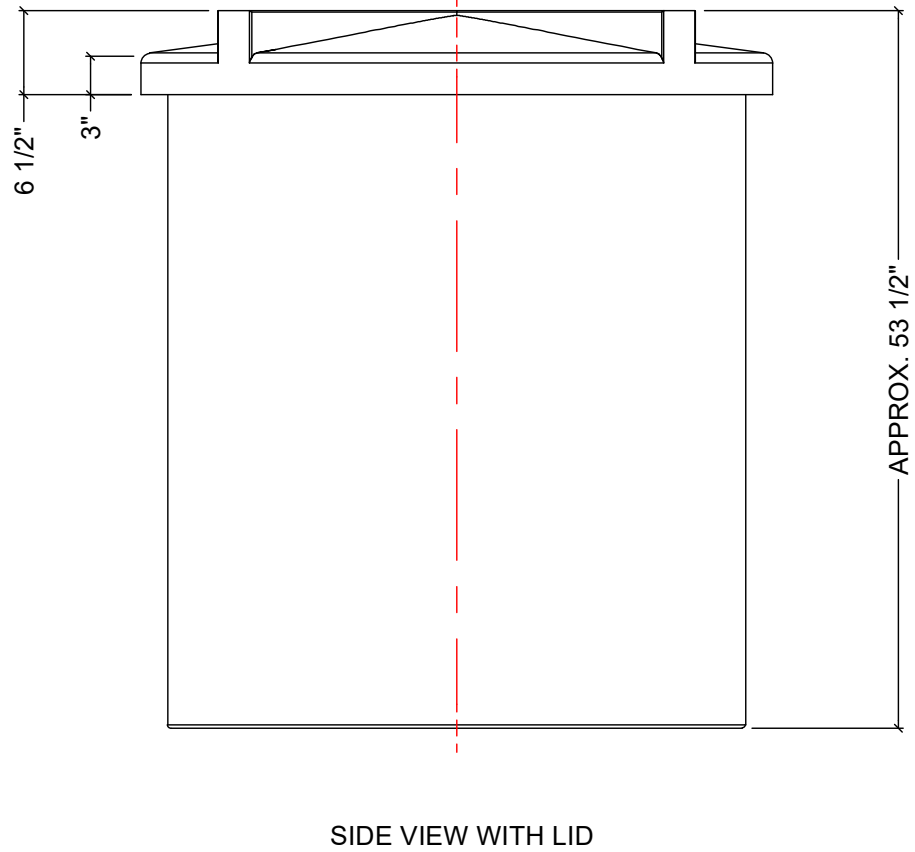
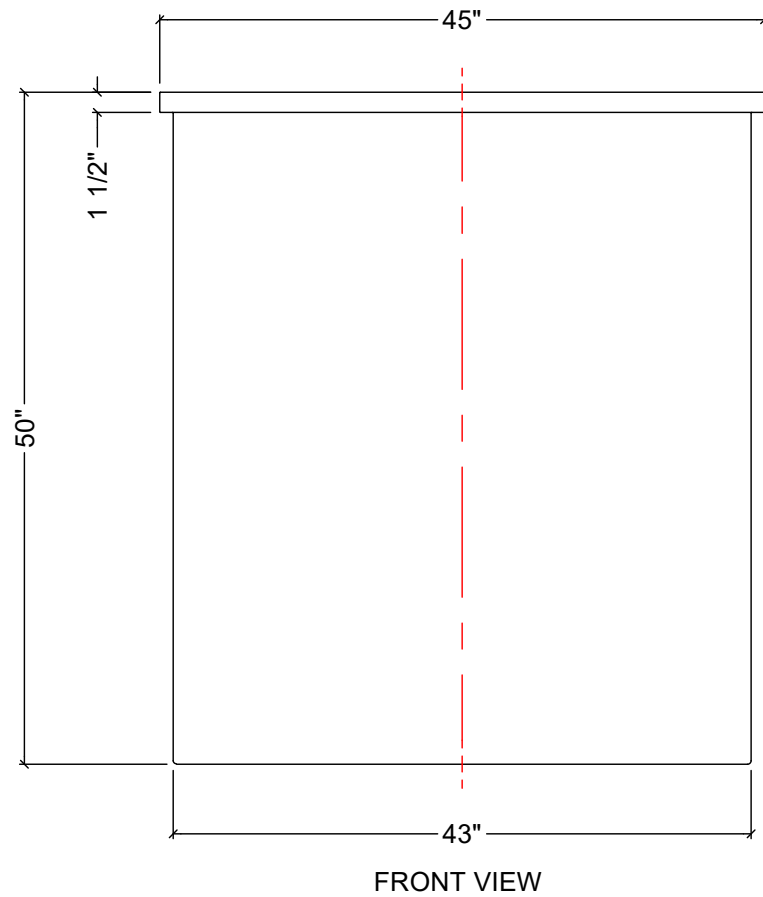

REV	DATE	DESCRIPTION	BY	APPD	REVD
REVISIONS					
CUSTOMER					
TITLE		ACO JOB NO:			
240 I.G. OPEN TOP TANK WITH LID		PURCHASE ORDER NO:			
		PURCHASER'S EQUIP. NO:			
THIS DRAWING IS THE PROPERTY OF ACO CONTAINER SYSTEMS LTD. AND SHALL NOT BE COPIED OR TRANSFERRED WITHOUT THE WRITTEN CONSENT OF ACO CONTAINER SYSTEMS LTD.					
ENGINEERS SEAL		ACO CONTAINER SYSTEMS LTD. <small>PICKERING - ONTARIO - CANADA</small> ACO CONTAINER SYSTEMS LTD. 794 MCKAY RD. PICKERING, ONTARIO, CANADA L1W 2Y4 TEL. 905-683-8222 FAX 905-683-2969			
		DESIGNED			
		DRAWN	WM		
		CHECKED			
		APPROVED			
		SCALE	N.T.S.		
		DATE	27-05-09		
DWG No		OT-240-L			REV 0