

TOP VIEW

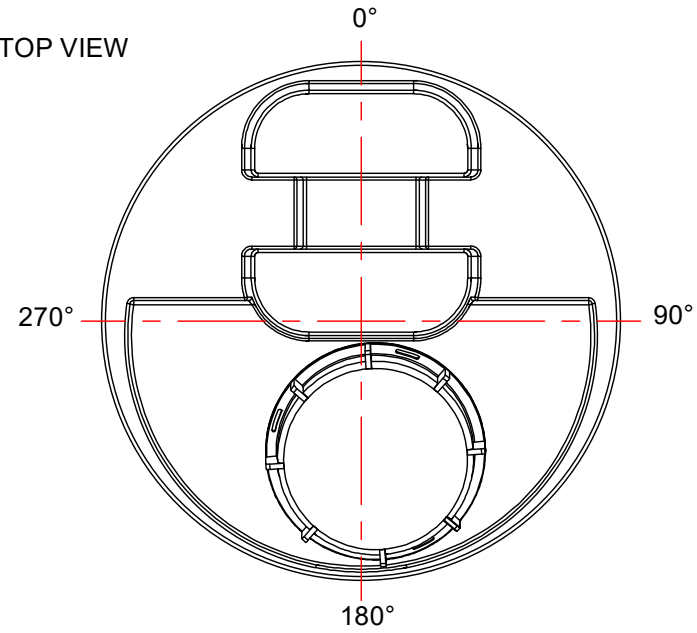

NOTES:

1. TANK IS MANUFACTURED FROM POLYETHYLENE (PE).
2. RATED FOR STORING LIQUIDS WITH A SPECIFIC GRAVITY OF 1.5SG OR LOWER (ALSO AVAILABLE IN 1.9SG & 2.2SG)
3. ALL TANK DIMENSIONS ARE SUBJECT TO A +/-3% TOLERANCE.
4. ALL EXTERNAL PIPING AND ACCESSORIES MUST BE FULLY SUPPORTED AND FLEXIBLE TO AVOID STRESSING THE TANK.

MATERIALS LIST			
ITEMS	PART#	DESCRIPTION	NOTES
A	PTB-100	22 IG / 26 USG / 100 L TOTE BARREL	
B		5 1/2" THREADED LID	

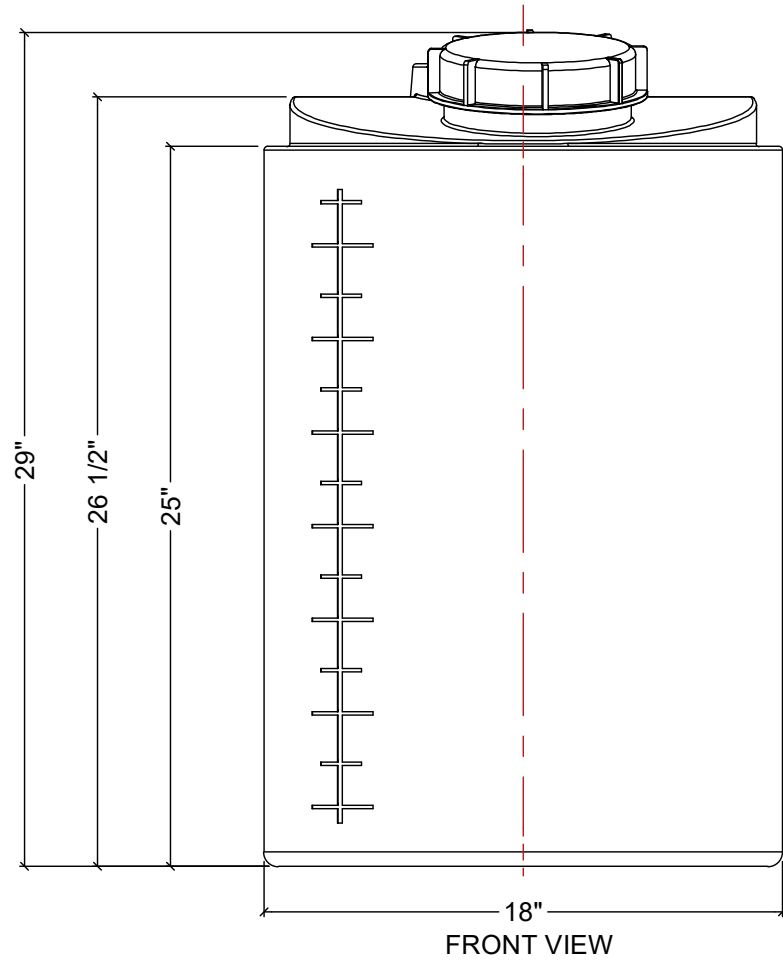

FRONT VIEW

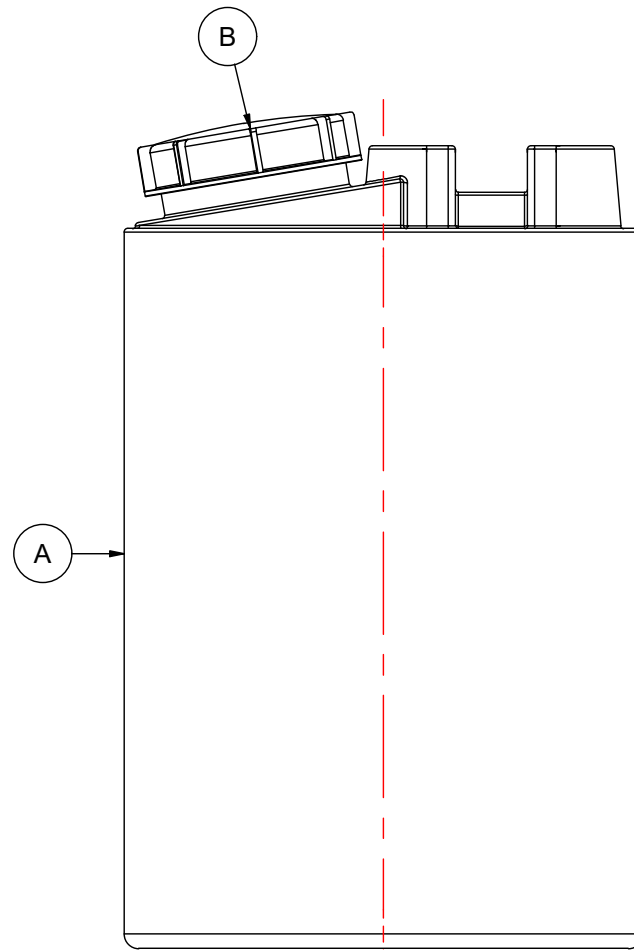

SIDE VIEW

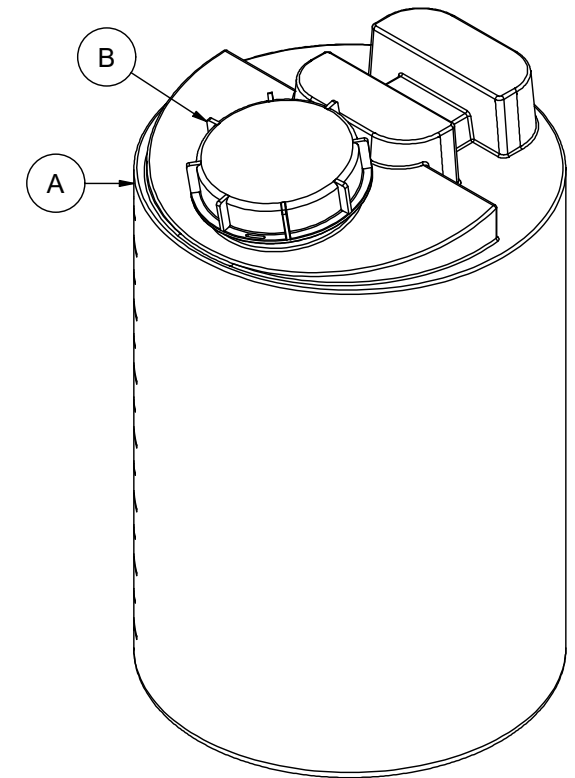

REV	DATE	DESCRIPTION	BY	APPD	REVD	
REVISIONS						
CUSTOMER						
TITLE 22 IG / 26 USG / 100 L TOTE BARREL			ACO JOB NO: PURCHASE ORDER NO: PURCHASER'S EQUIP. NO:			
THIS DRAWING IS THE PROPERTY OF ROTOPLAST INC. AND SHALL NOT BE COPIED OR TRANSFERRED WITHOUT THE WRITTEN CONSENT OF ROTOPLAST INC.						
ENGINEERS SEAL		ACO CONTAINER SYSTEMS DIVISION OF ROTOPLAST INC.				
<small>PICKERING - ONTARIO - CANADA</small>						
<small>ACO CONTAINER SYSTEMS DIVISION OF ROTOPLAST INC. 794 MCKAY RD. PICKERING, ONTARIO, CANADA TEL. 905-683-8222 FAX 905-683-2969</small>				DESIGNED		
				DRAWN		
				CHECKED		
				APPROVED		
				SCALE	N.T.S.	
				DATE	04-16-2024	
<small>DWG No</small>		PTB-100-2024			<small>REV</small>	0