

- NOTES:
1. TANK IS MANUFACTURED FROM POLYETHYLENE (PE).
 2. RATED FOR STORING LIQUIDS WITH A SPECIFIC GRAVITY OF 1.5SG OR LOWER (ALSO AVAILABLE IN 1.9SG & 2.2SG)
 3. ALL TANK DIMENSIONS ARE SUBJECT TO A +/-3% TOLERANCE.
 4. ALL EXTERNAL PIPING AND ACCESSORIES MUST BE FULLY SUPPORTED AND FLEXIBLE TO AVOID STRESSING THE TANK.

MATERIALS LIST			
ITEMS	PART#	DESCRIPTION	NOTES
A	PTB-400	88 IG / 106 USG / 400L TOTE BARREL	
B		5 1/2" THREADED LID	

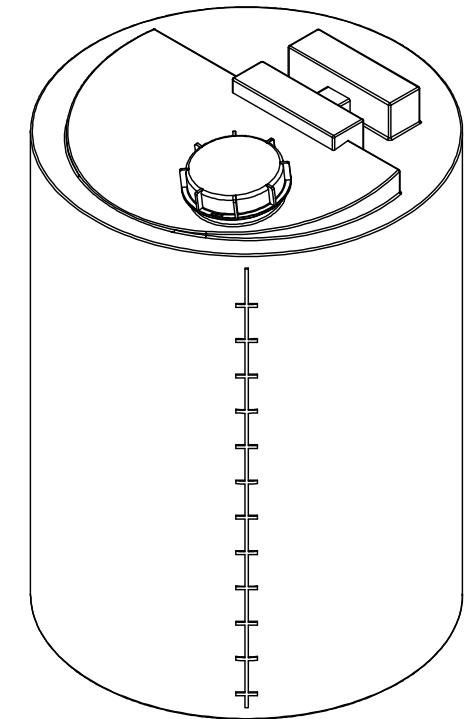

REV	DATE	DESCRIPTION	BY	APPD	REVD
REVISIONS					
CUSTOMER					
TITLE			ACO JOB NO:		
88 IG / 106 USG / 400 L TOTE BARREL			PURCHASE ORDER NO:		
			PURCHASER'S EQUIP. NO:		
THIS DRAWING IS THE PROPERTY OF ROTOPLAST INC. AND SHALL NOT BE COPIED OR TRANSFERRED WITHOUT THE WRITTEN CONSENT OF ROTOPLAST INC.					
ENGINEERS SEAL		ACO CONTAINER SYSTEMS DIVISION OF ROTOPLAST INC. <small>PICKERING - ONTARIO - CANADA</small> ACO CONTAINER SYSTEMS DIVISION OF ROTOPLAST INC. 794 MCKAY RD. PICKERING, ONTARIO, CANADA TEL. 905-683-8222 FAX 905-683-2969			
		DESIGNED			
		DRAWN			gt
		CHECKED			
		APPROVED			
		SCALE			N.T.S.
		DATE			04-16-2024
DWG No		PTB-400-2024			REV 0