

TOP VIEW

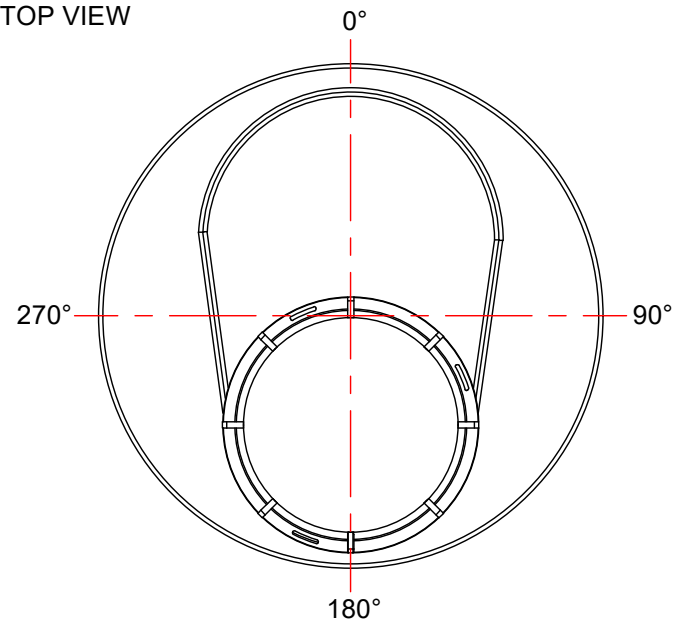

NOTES:

1. TANK IS MANUFACTURED FROM POLYETHYLENE (PE).
2. RATED FOR STORING LIQUIDS WITH A SPECIFIC GRAVITY OF 1.5SG OR LOWER ( ALSO AVAILABLE IN 1.9SG & 2.2SG)
3. ALL TANK DIMENSIONS ARE SUBJECT TO A +/-3% TOLERANCE.
4. ALL EXTERNAL PIPING AND ACCESSORIES MUST BE FULLY SUPPORTED AND FLEXIBLE TO AVOID STRESSING THE TANK.

MATERIALS LIST			
ITEMS	PART#	DESCRIPTION	NOTES
A	PTB-60	13 IG / 16 USG / 60L TOTE BARREL	
B		5 1/2" THREADED LID	

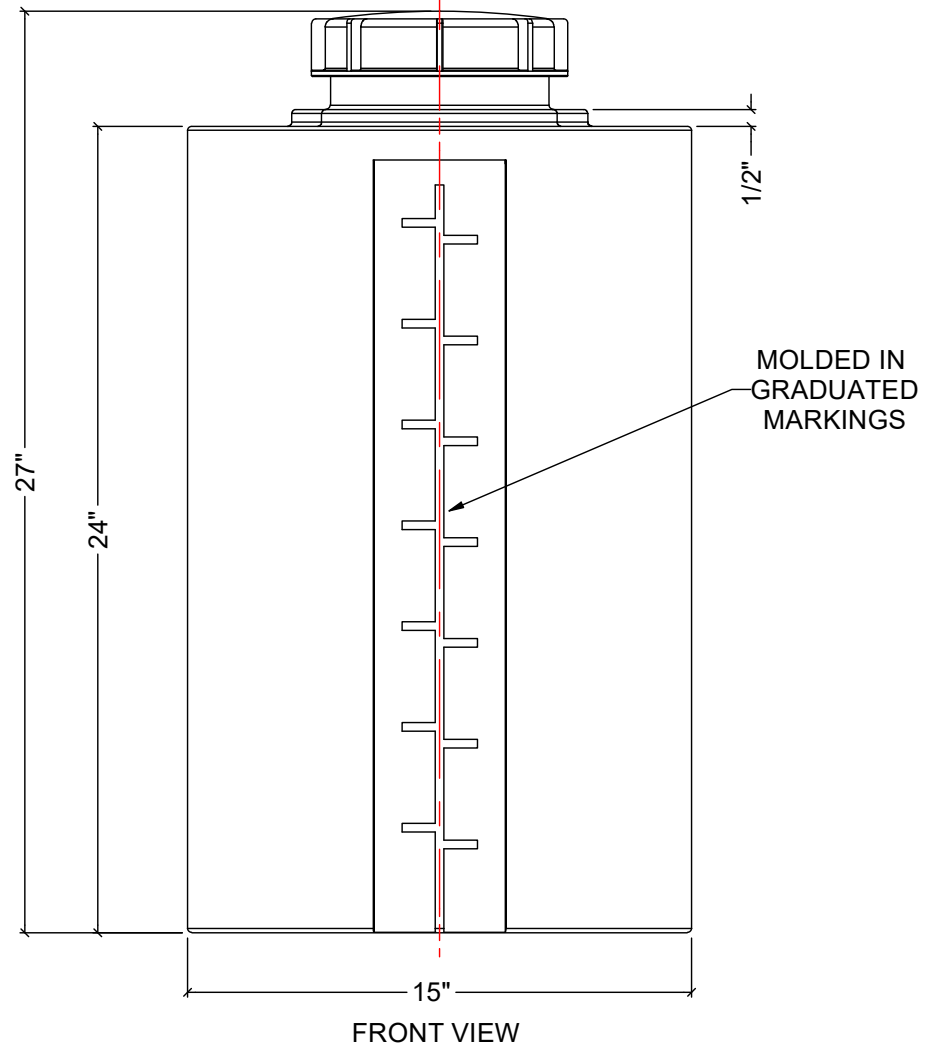

FRONT VIEW

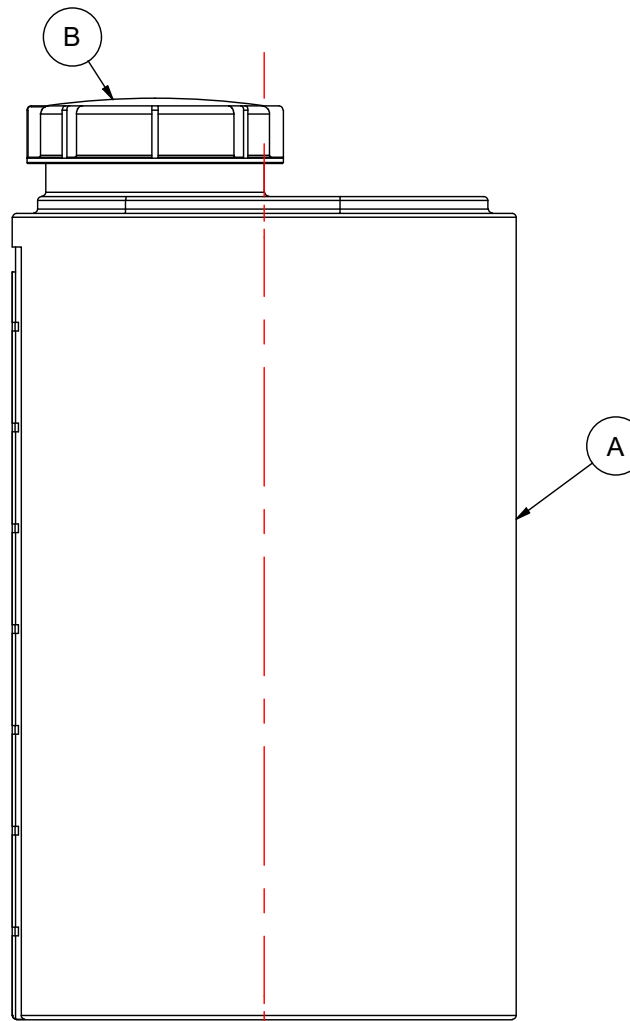

SIDE VIEW

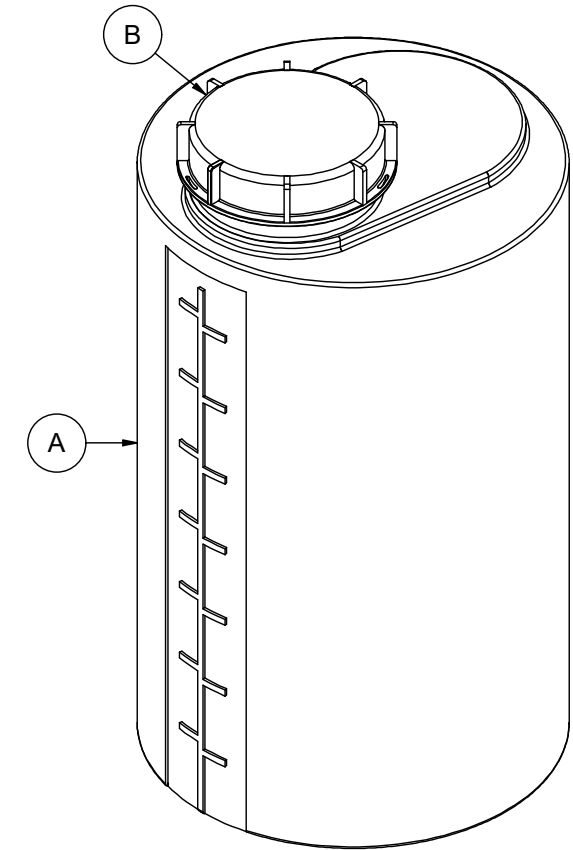

REV	DATE	DESCRIPTION	BY	APPD	REVD
REVISIONS					
CUSTOMER					
TITLE			ACO JOB NO:		
13 IG / 16 USG / 60L TOTE BARREL			PO#:		
			EQUIP. NO:		
THIS DRAWING IS THE PROPERTY OF ROTOPLAST INC. AND SHALL NOT BE COPIED OR TRANSFERRED WITHOUT THE WRITTEN CONSENT OF ROTOPLAST INC.			 <b>ACO CONTAINER SYSTEMS</b> <i>A division of Rotoplast Inc.</i>		
		DRAWN			
		CHECKED			
		APPROVED			
		SCALE		N.T.S.	
		DATE		04-16-2024	
DWG No			PTB-60-2024		REV 0