

TOP VIEW

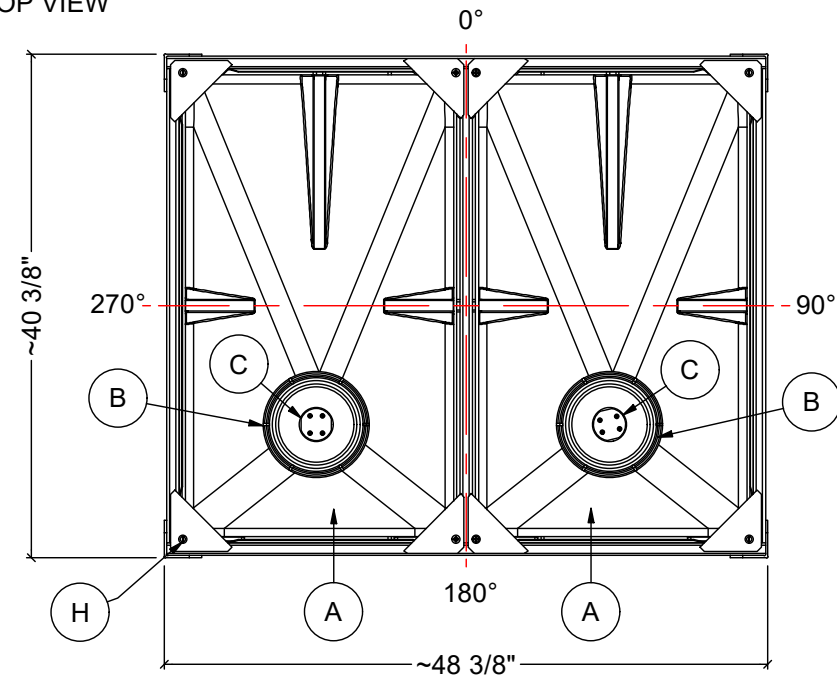

NOTES:

1. CAPACITY PER TANK: 630 L (138 IG / 166 USG)
2. TARE WEIGHT: 695 LBS (315 KG)
3. PRIMARY MARKINGS: U.N. 31HA1/Y/

STACKING BRACKET DETAIL (H)

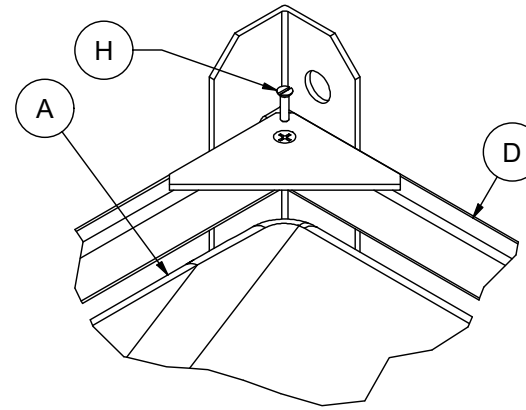

MATERIALS LIST

ITEM	ITEM QTY	DESCRIPTION	NOTES
A	2	PTC-135 HDPE BOTTLE	
B	2	6" HDPE THREADED LID WITH GASKET (EPDM OR VITON) AND TIE DOWN	
C	2	2" COMBI-VENT - VACUUM AND PRESSURE RELIEF (OPTIONAL)	IN LID
D	1	STEEL FRAME WITH 12" KICK PLATES AND VALVE PROTECTION GATES	
E	2	2" BALL VALVE (POLYPRO OR STAINLESS STEEL) WITH GASKET (EPDM OR VITON)	FNPT OR CAMLOC
F	2	VALVE MOUNTING HARDWARE KIT	
G	2	BLACK POLY FRAME PILLOW	
H	4	FRAME CORNER STACKING BRACKET WITH SCREW	
J	1	ALUMINUM U.N. FRAME TAG	

INNER SUPPORT PLATE

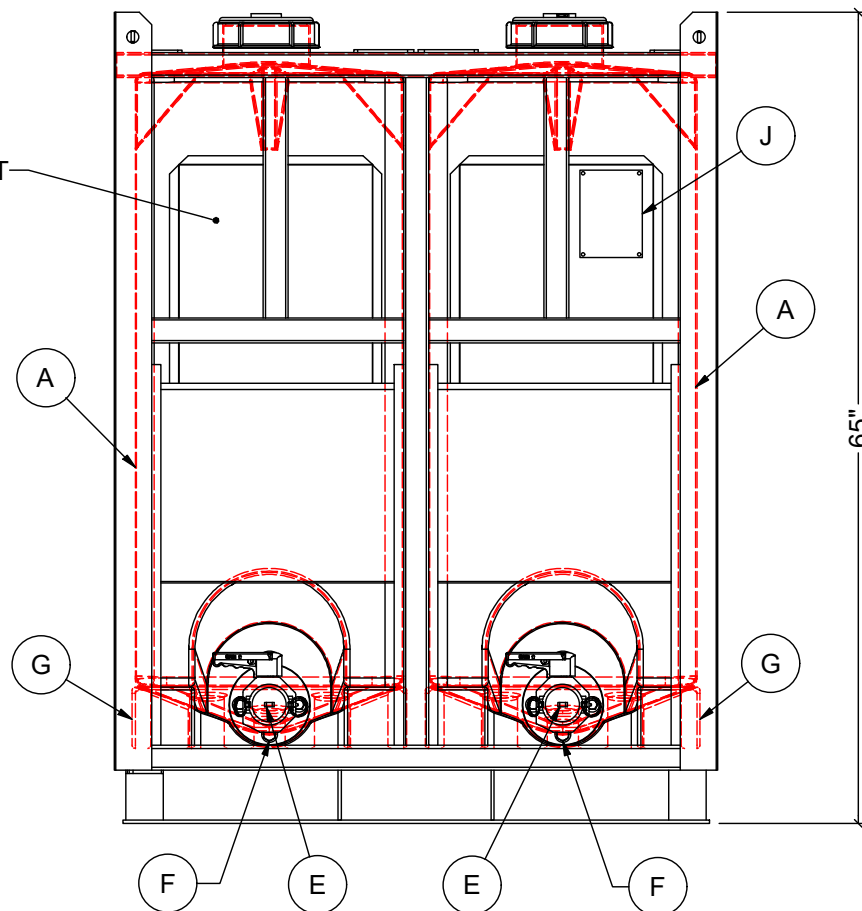

FRONT VIEW

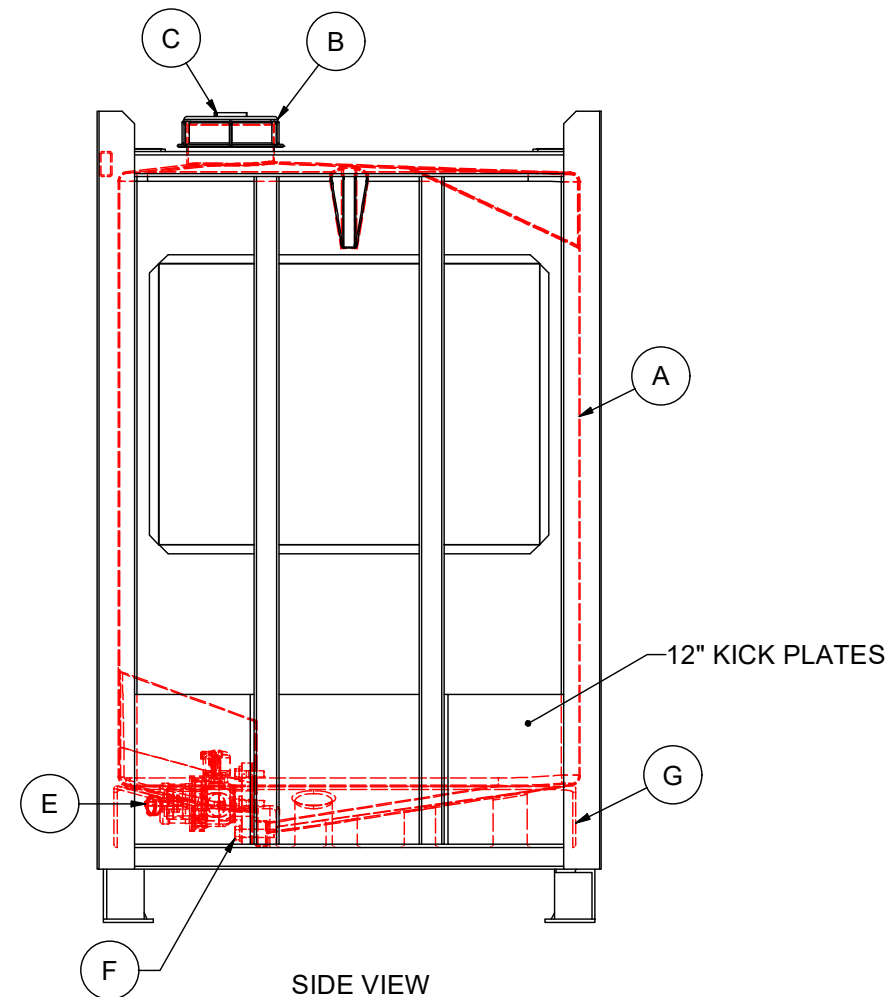

SIDE VIEW

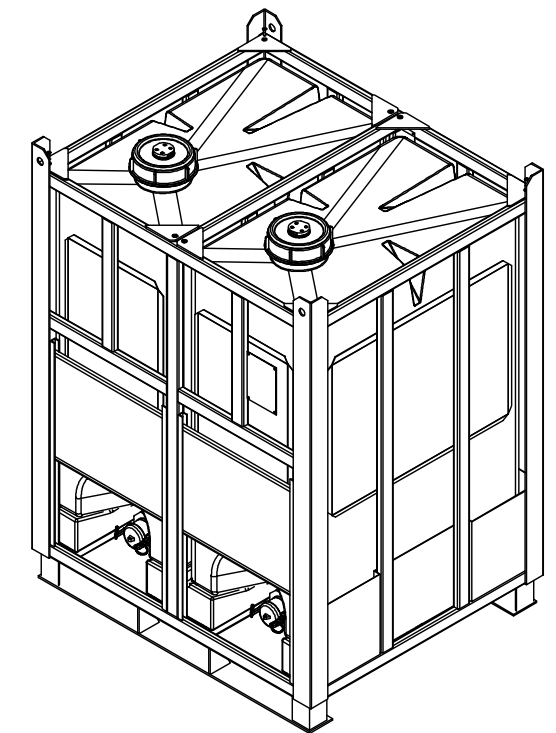

REV	DATE	DESCRIPTION	BY	APPD	REVD
1	2018-07-11	UPDATED VOLUME AND DIMENSIONS	WM		

REVISIONS

CUSTOMER

TITLE: PTC-2-135 PALLET TANK W/ TWO 135 IG TANKS IN ONE STEEL FRAME
 ACO JOB NO:
 PO#:
 EQUIP. NO:

THIS DRAWING IS THE PROPERTY OF ROTOPLAST INC. AND SHALL NOT BE COPIED OR TRANSFERRED WITHOUT THE WRITTEN CONSENT OF ROTOPLAST INC.



ENGINEERS SEAL	ACO CONTAINER SYSTEMS DIVISION OF ROTOPLAST INC. 794 MCKAY ROAD PICKERING, ONTARIO, CANADA TEL: 905-683-8222 WEB: ACOTAINERS.COM	DESIGNED DRAWN CHECKED APPROVED SCALE DATE	WM N.T.S. 04-04-16
----------------	-------------------------------------------------------------------------------------------------------------------------------------------------	-----------------------------------------------------------	--------------------------