

MATERIALS LIST		
ITEMS	DESCRIPTION	NOTES
A	RT-100 TANK	
B	5 1/2" THREADED LID	

NOTES:
 1. TANK IS MANUFACTURED FROM POLYETHYLENE (PE).
 2. ALL TANK DIMENSIONS ARE SUBJECT TO A +/-3% TOLERANCE.
 3. ALL EXTERNAL PIPING AND ACCESSORIES MUST BE FULLY SUPPORTED AND FLEXIBLE TO AVOID STRESSING THE TANK.

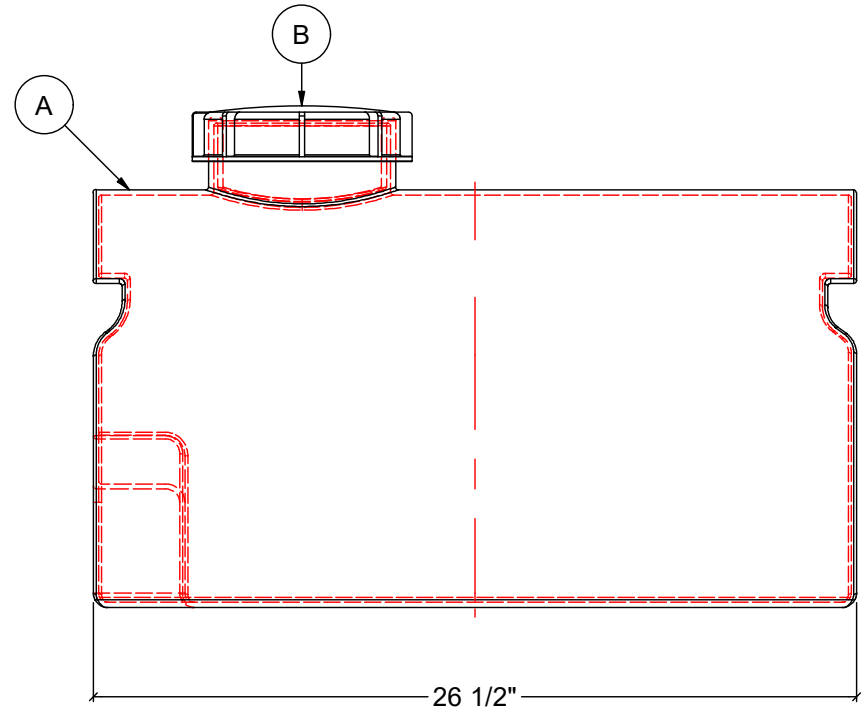
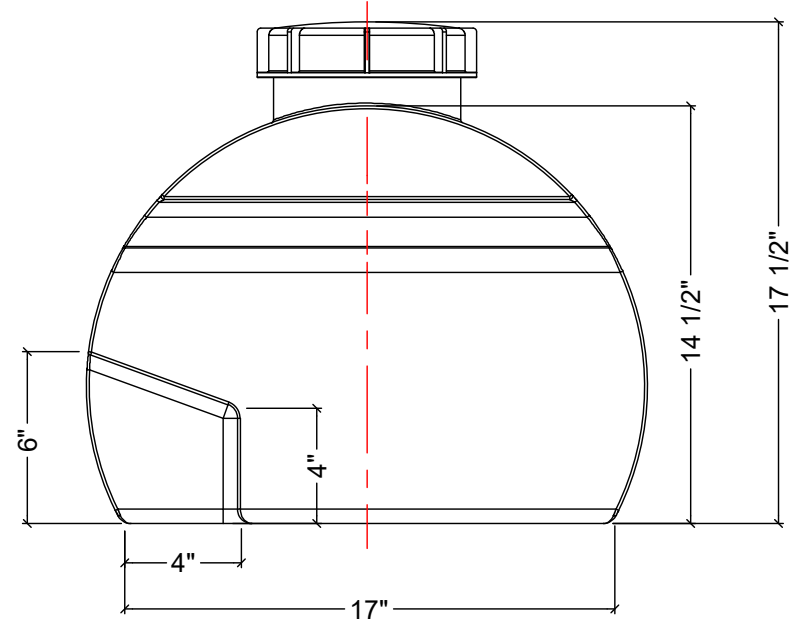
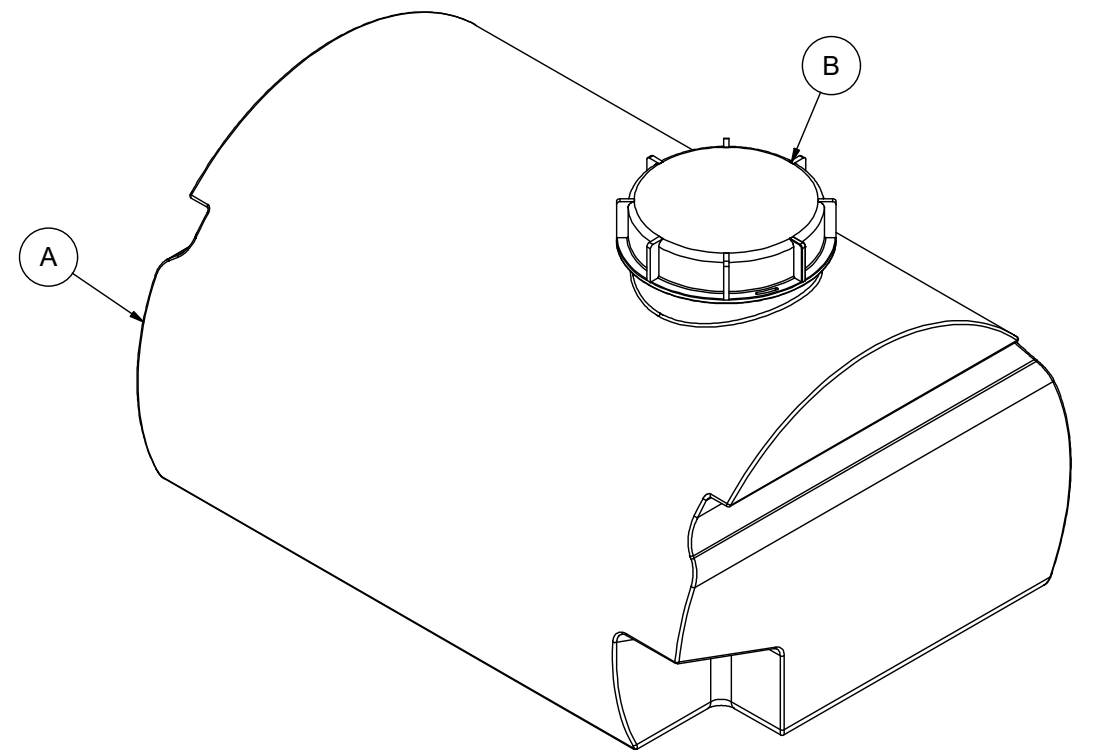
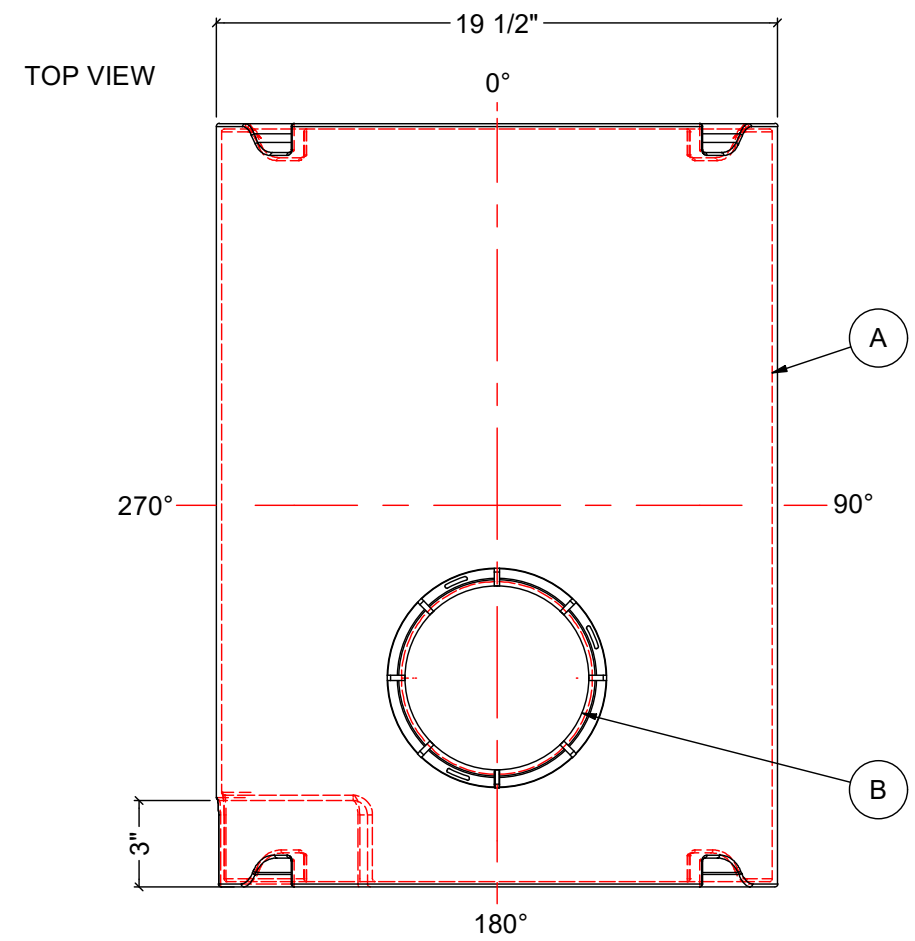

REV	DATE	DESCRIPTION	BY	APPD	REVD
REVISIONS					
CUSTOMER					
TITLE		ACO JOB NO:			
100 L ROUND TANK		PURCHASE ORDER NO:			
		PURCHASER'S EQUIP. NO:			
THIS DRAWING IS THE PROPERTY OF ROTOPLAST INC. AND SHALL NOT BE COPIED OR TRANSFERRED WITHOUT THE WRITTEN CONSENT OF ROTOPLAST INC.					
ENGINEERS SEAL		ACO CONTAINER SYSTEMS DIVISION OF ROTOPLAST INC. <small>PICKERING - ONTARIO - CANADA</small> ACO CONTAINER SYSTEMS DIVISION OF ROTOPLAST INC. 794 MCKAY RD. PICKERING, ONTARIO, CANADA TEL. 905-683-8222 FAX 905-683-2969 <small>DWG No</small>			
		DESIGNED			
		DRAWN	WM		
		CHECKED			
		APPROVED			
		SCALE	N.T.S.		
		DATE	04-04-16		
					REV 0

FRONT VIEW

SIDE VIEW

RT-100